

Champion Compact

Montageanleitung

Assembly instructions

Notice de montage

Istruzioni per il montaggio

Instrucciones de montaje

Инструкция по монтажу

组装说明

05. 2020

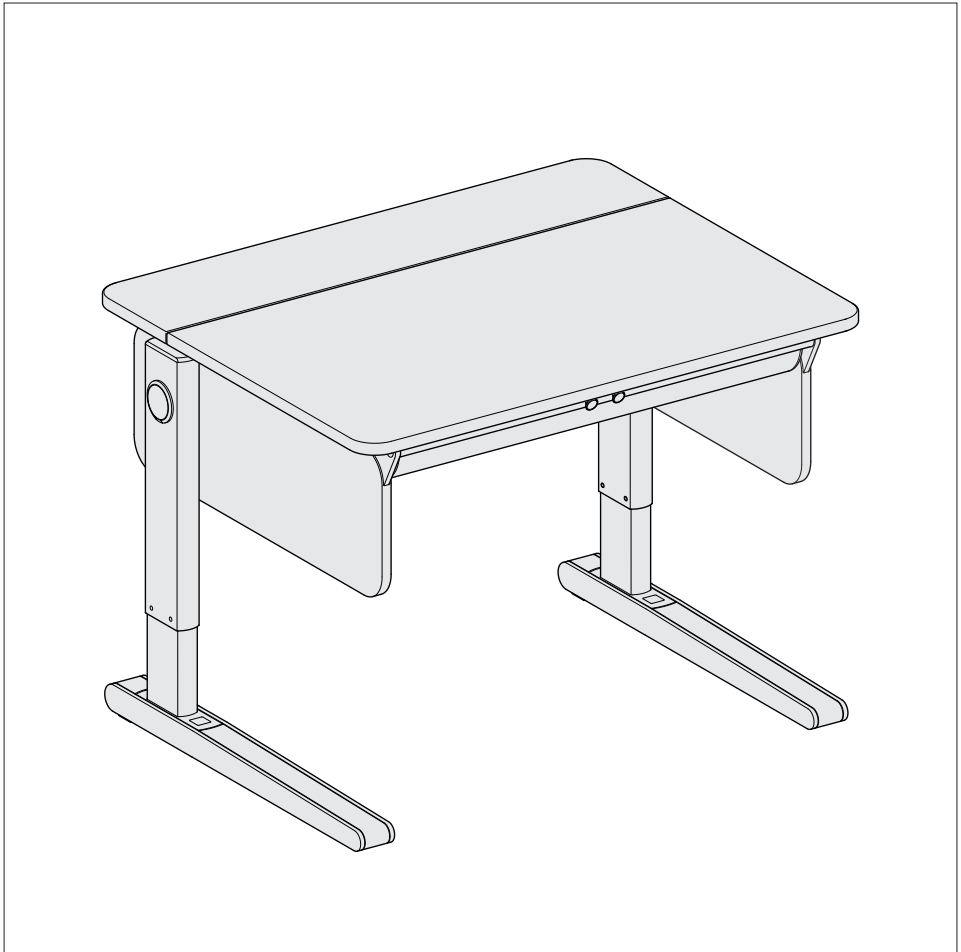

D Sicherheitshinweise

- ⚠ Die Montage darf nur durch geeignete Personen erfolgen.
- ⚠ Das Möbel darf nur für seinen bestimmungsgemäßen Gebrauch verwendet werden.
- ⚠ Kleinteile (Schmuck- und Farbelemente) und Zugband für die Comfort-Höhenverstellung (Jojo) von Kleinkindern fernhalten.

GB Safety instructions

- ⚠ Assembly may only be made by qualified persons.
- ⚠ The furniture is only to be used for its intended purpose.
- ⚠ Keep small items (decorative and colour elements) and the pull strap for comfort height adjustment (yoyo) out of the reach of small children.

F Consignes de sécurité

- ⚠ Le montage doit être confié uniquement à des personnes compétentes.
- ⚠ Ce meuble doit servir exclusivement à l'usage qui en est fait habituellement.
- ⚠ Conserver les petites pièces (éléments décoratifs et éléments de couleur) ainsi que le cordon de serrage pour le réglage en hauteur Comfort (yoyo) hors de portée des enfants en bas âge.

I Norme di sicurezza

- ⚠ Fare eseguire il montaggio esclusivamente da persone idonee.
- ⚠ Utilizzare questo mobile esclusivamente per l'uso previsto.
- ⚠ Tenere i pezzi piccoli (elementi decorativi e colorati) e il tirantino per la regolazione in altezza Comfort (yo-yo) lontano dalla portata dei bambini.

E

Indicaciones de seguridad

- ⚠ El montaje sólo podrá ser ejecutado por personas aptas para el mismo.
- ⚠ El mueble sólo podrá ser utilizado para un uso conforme a lo prescrito.
- ⚠ Mantenga las piezas pequeñas (elementos decorativos y cromáticos) y la cinta tirante para ajustar la altura de Comfort (yo-yó) fuera del alcance de los niños pequeños.

RUS

Указания по безопасности

- ⚠ Монтаж должен выполняться только лицами, имеющими необходимые навыки.
- ⚠ Мебель должна использоваться только по ее прямому назначению.
- ⚠ Малогабаритные детали (элементы декора и цвета), так же как и ключ JoJo для регулировки высоты Comfort, должны находиться вне досягаемости детей.

CHN

安全提示

- ⚠ 组装需要由专业人员完成。
- ⚠ 家具的使用要合理，要符合其用途。
- ⚠ 不要让小孩子接触小件（如装饰和色彩元素）和舒适调高用的拉带（YOYO）。

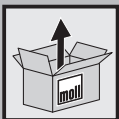

Alles auspacken und Inhalt auf Vollständigkeit prüfen

Unpack the contents and check for completeness

Déballez tout et vérifiez que le contenu est bien complet

Togliere la fornitura dall'imballo e accertarsi che non ci siano pezzi mancanti

Champion Compact

05. 2020

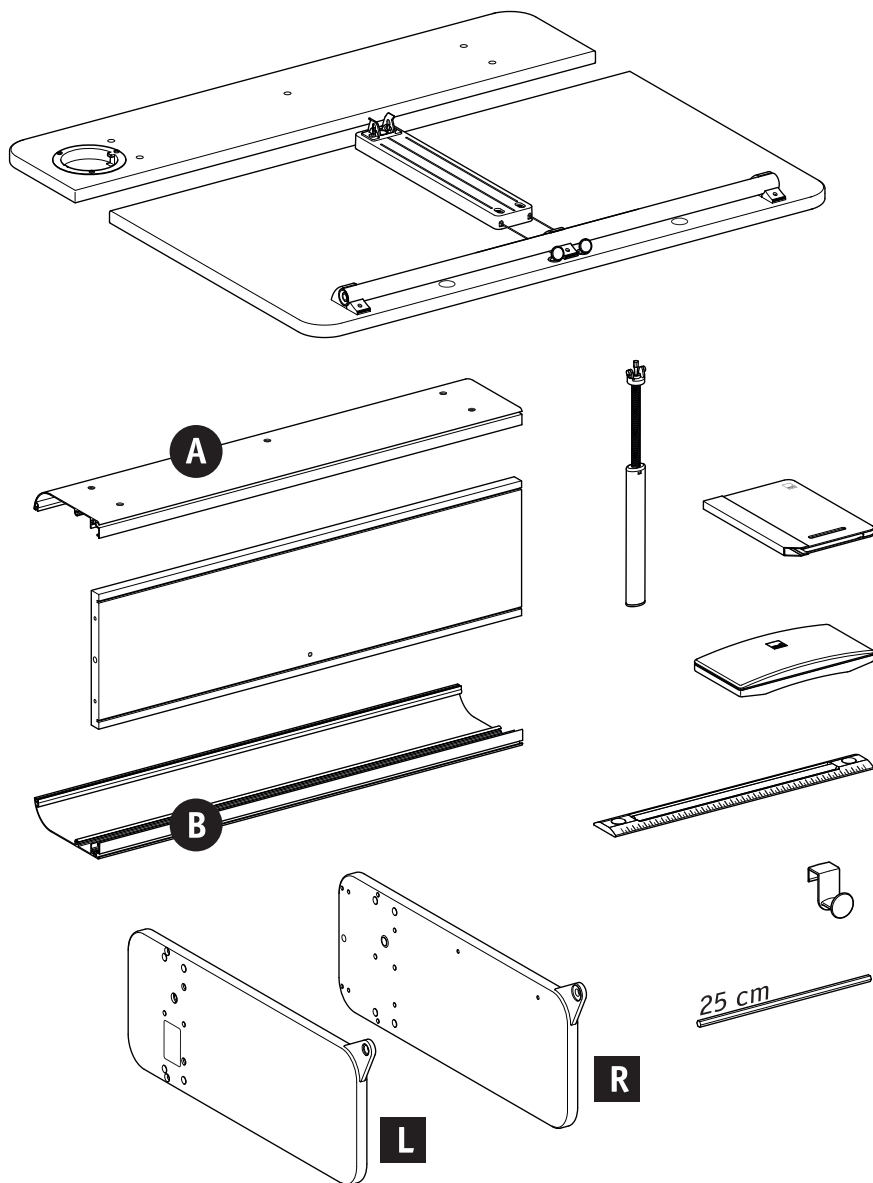

Desempaque todos los elementos y compruebe que no falta ninguno
 Распакуйте содержимое и проверьте его на комплектность
 拆开所有包装并检查是否齐全

- (D) Die Schrauben in dieser Reihenfolge verwenden.
- (GB) Use the screws in this sequence.
- (F) Utilisez les vis dans cette séquence.
- (I) Utilizzare le viti in questa sequenza.
- (E) Utilizar los tornillos en esta secuencia.
- (RUS) Использовать винты в этой последовательности.
- (CHN) 照此顺序安装使用螺钉。

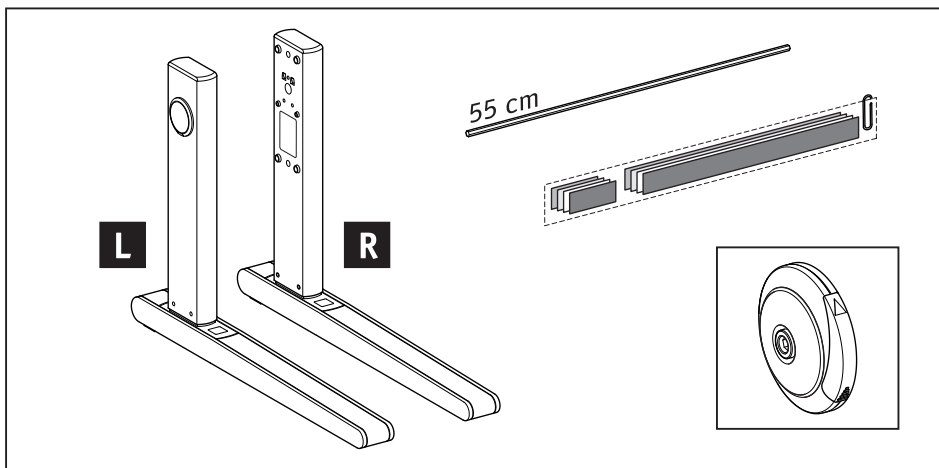
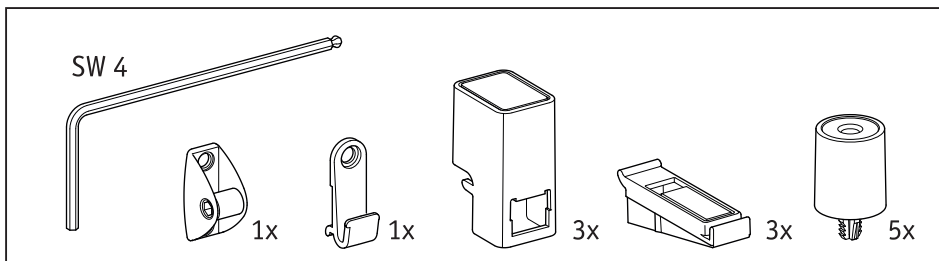
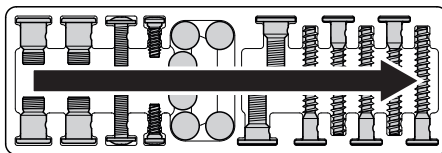
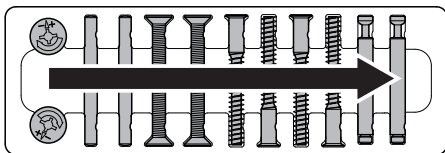

Montage Teil 1

Assembly Part 1

Montage partie 1

Montaggio parte 1

Montaje Parte 1

Монтаж Часть 1

组装 第1部分

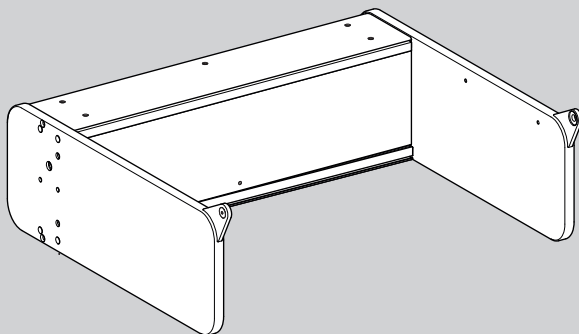

2x

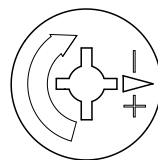
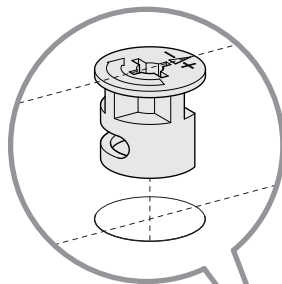
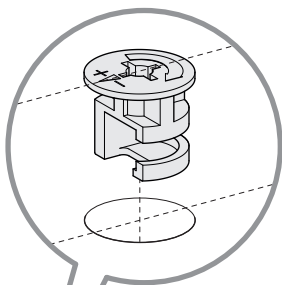
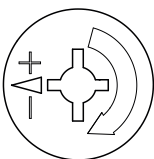

1

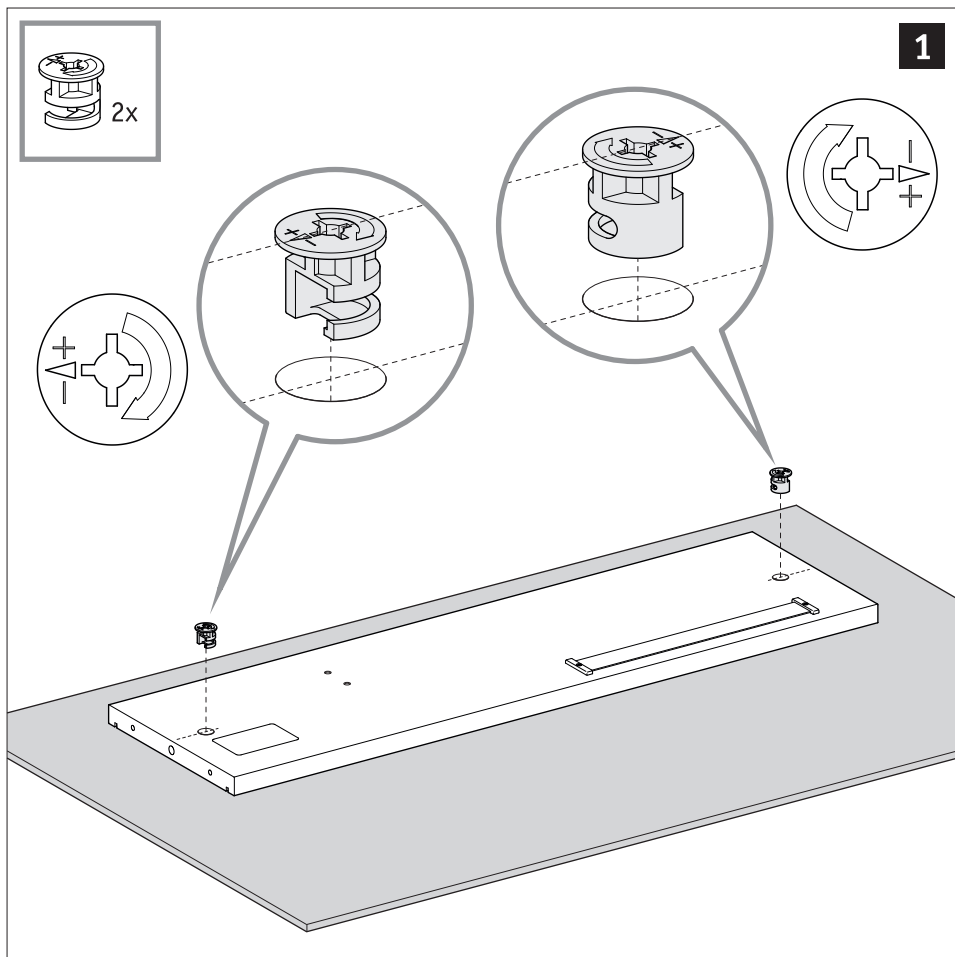

2

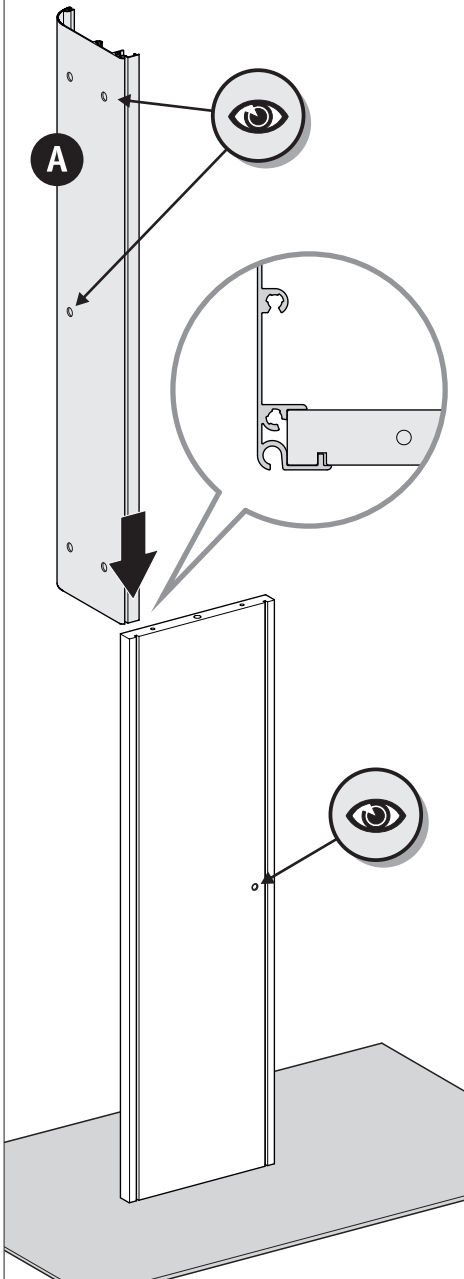

3

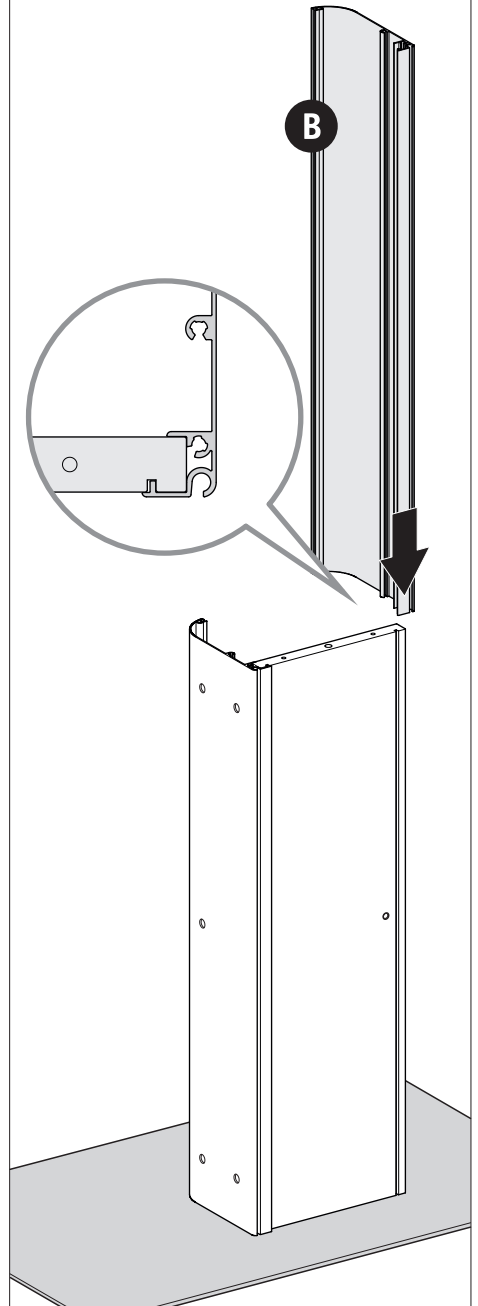

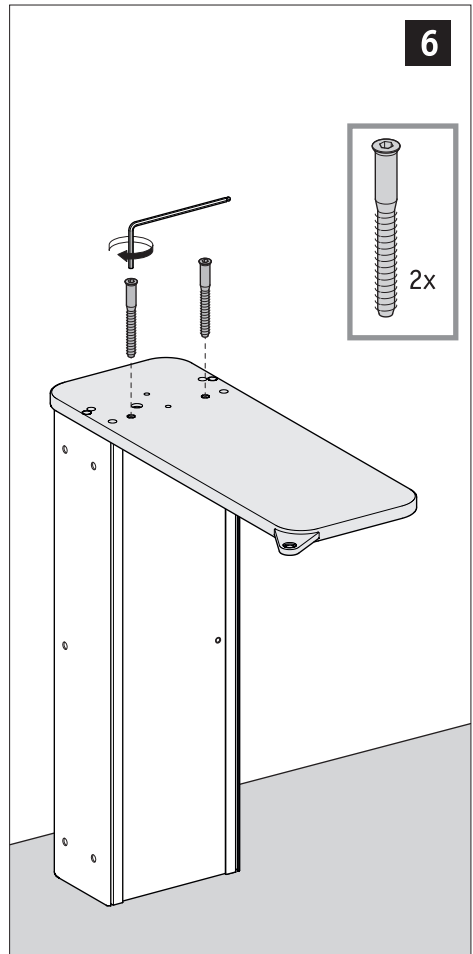
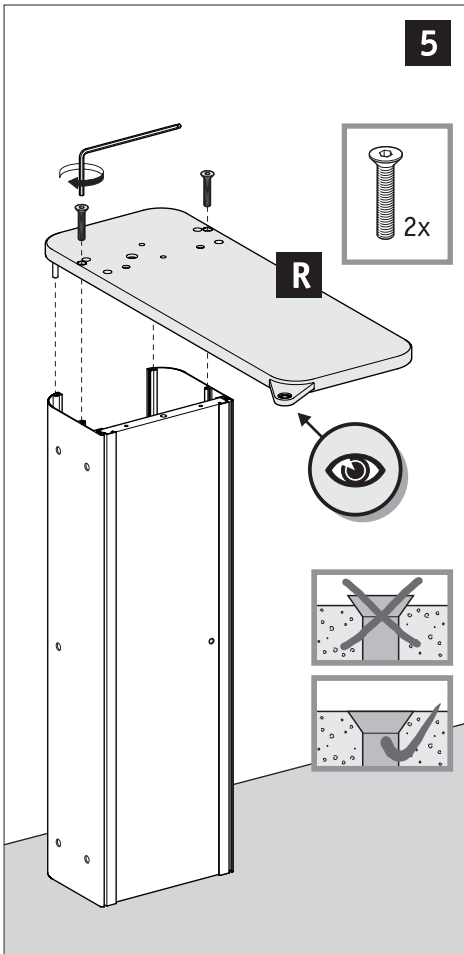
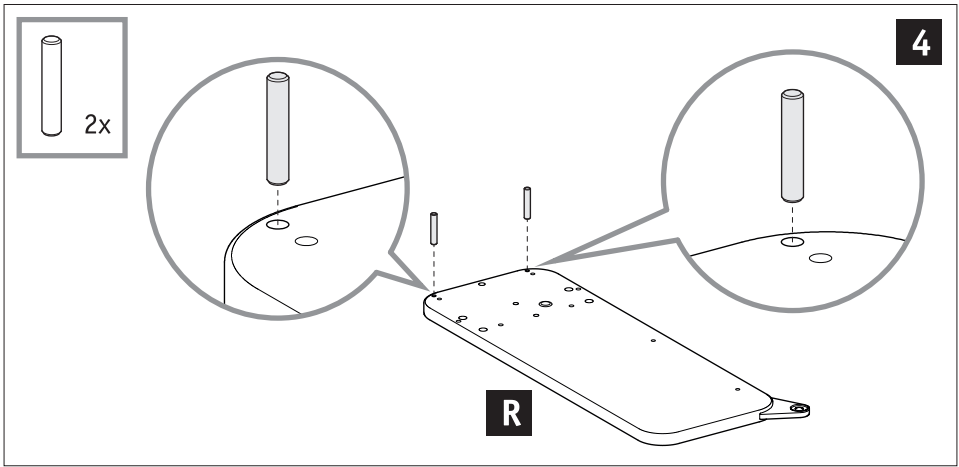

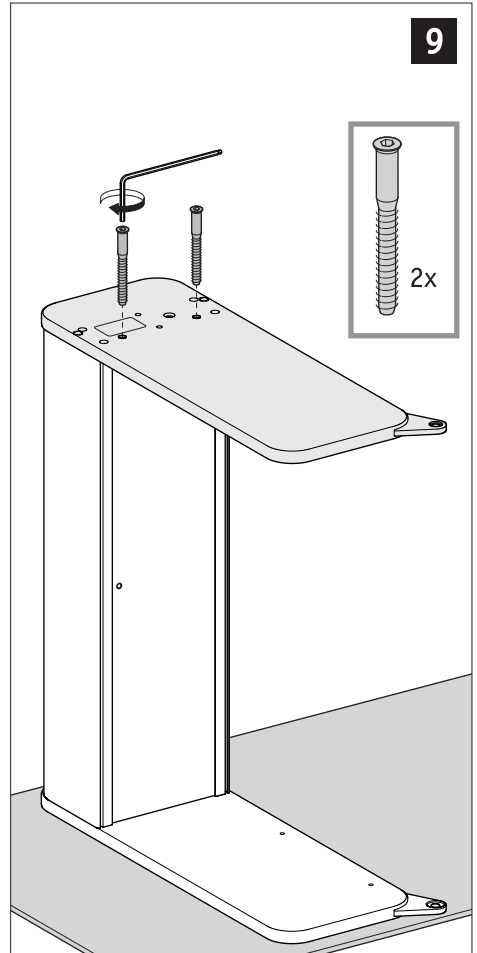
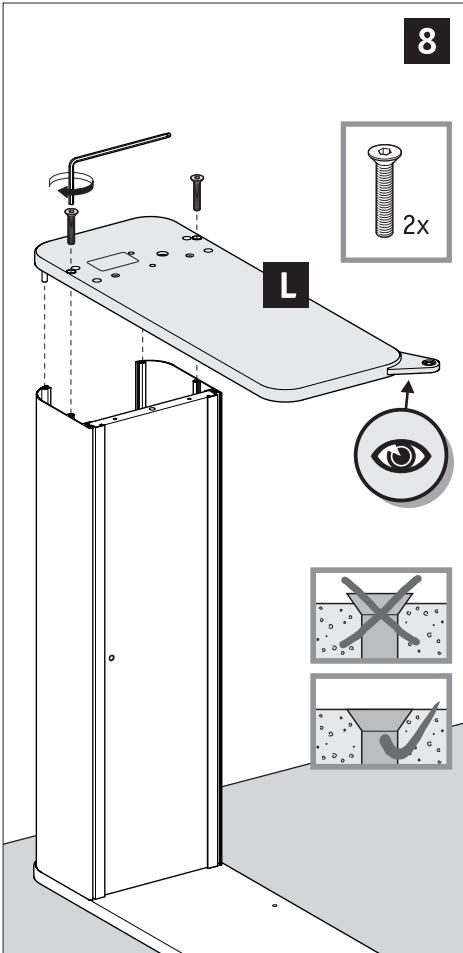
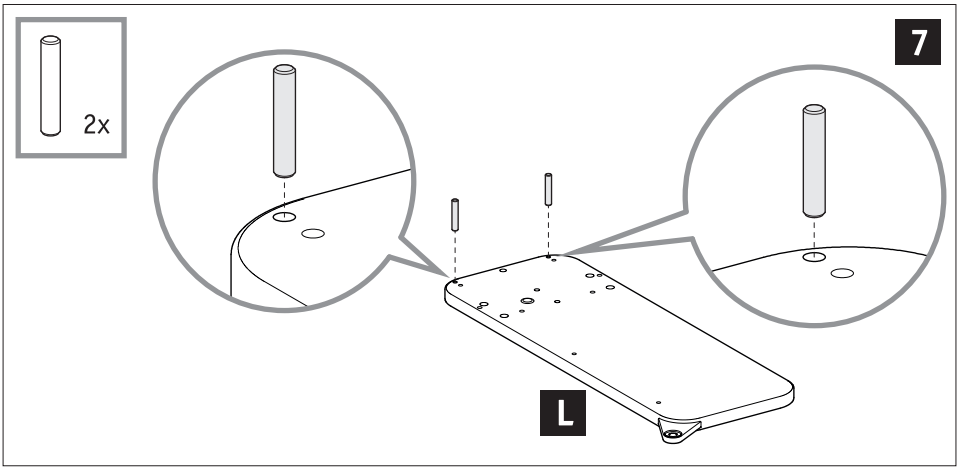



Farbwechsel
Color change
Changement de couleur
Cambiare i colori

Cambio de color
Замена цветных элементов
换色

1.

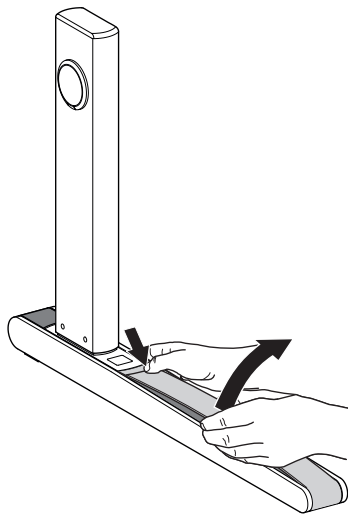
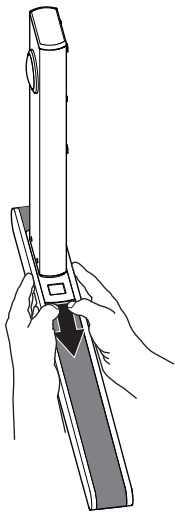

2.

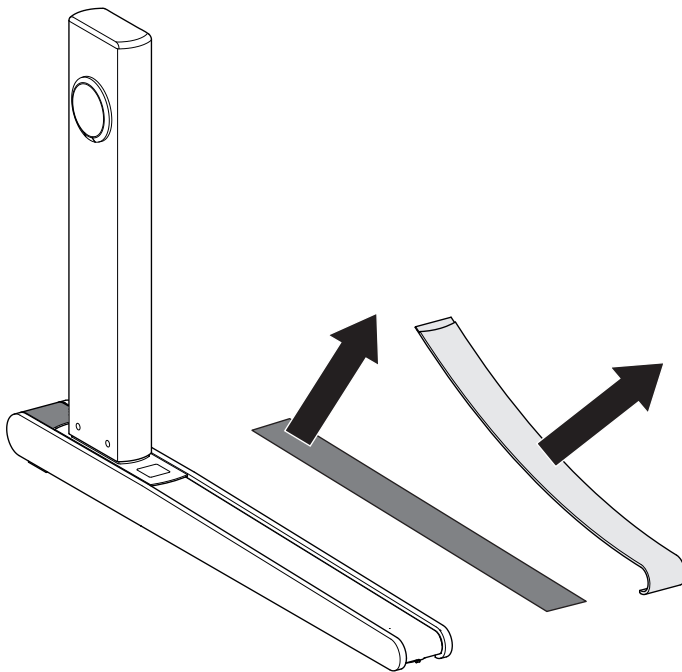

3.

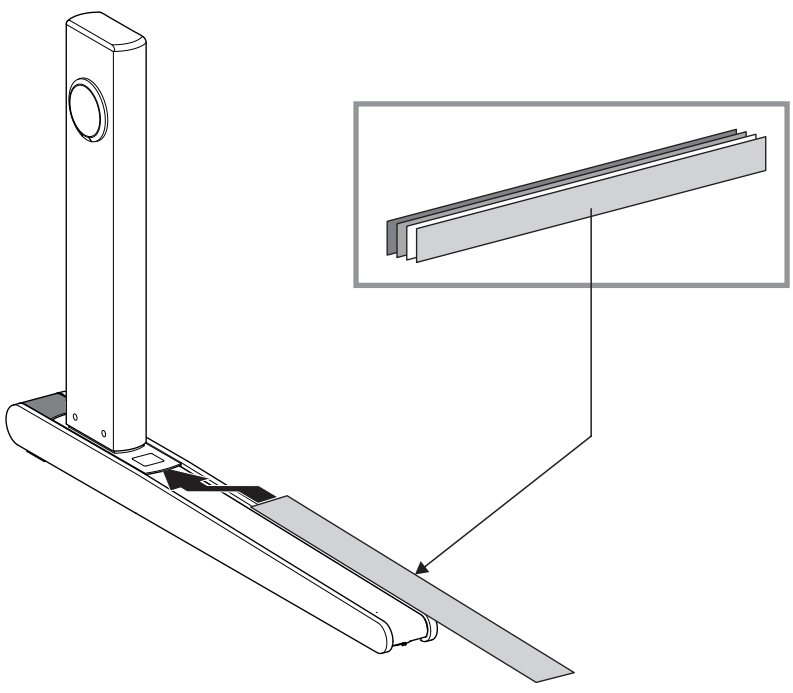

4.

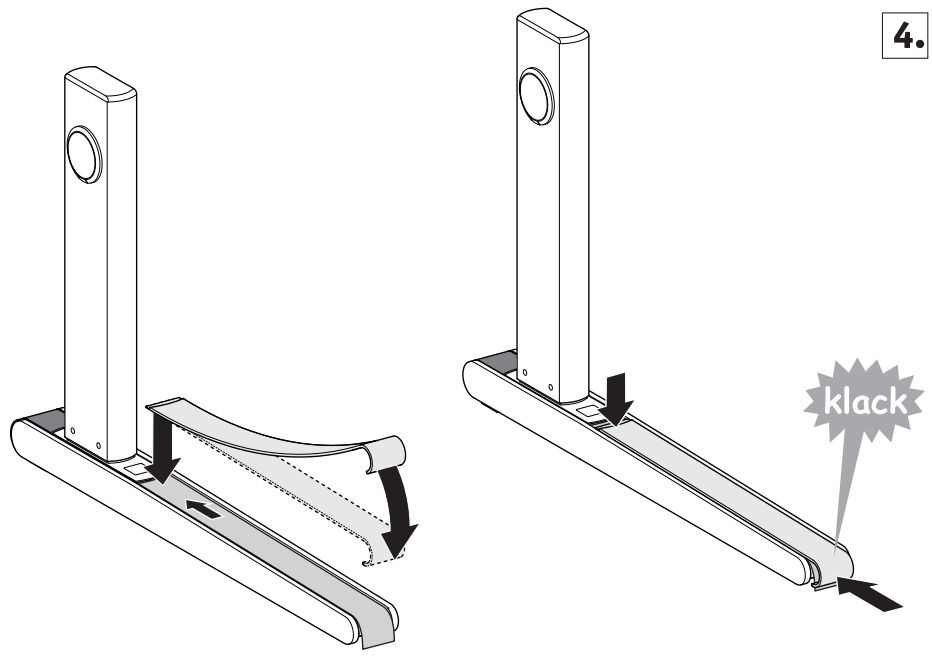

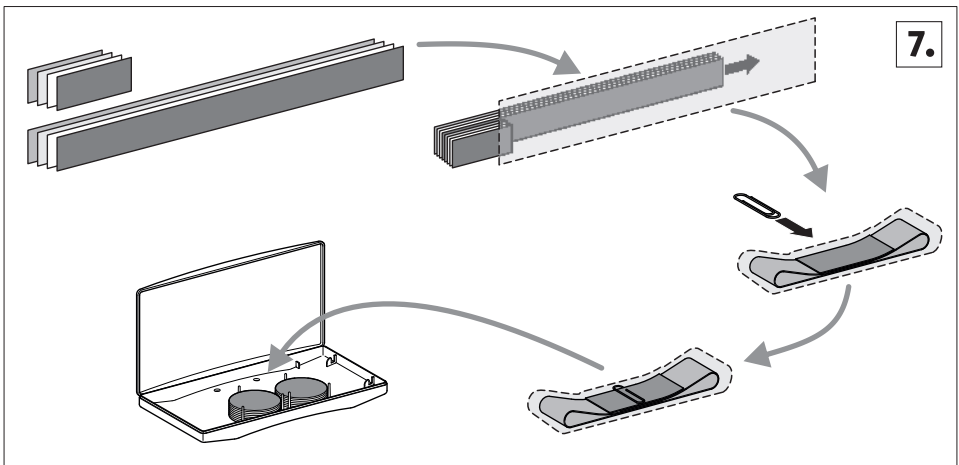
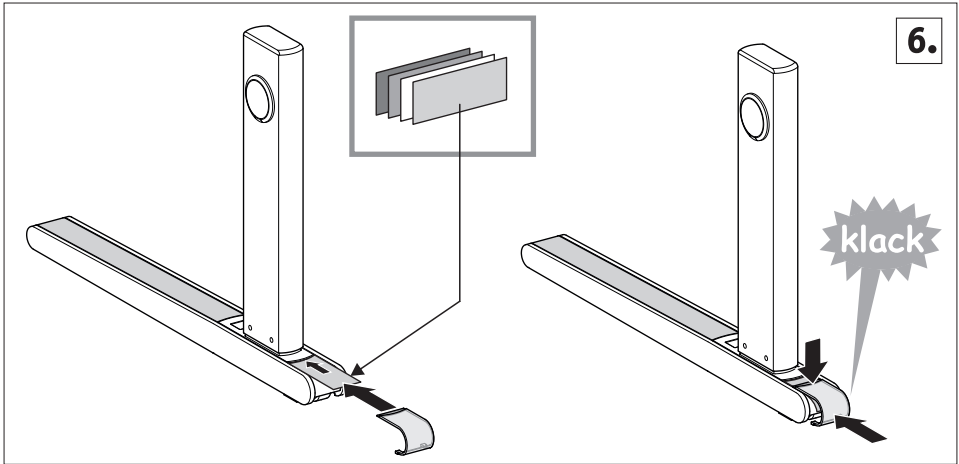
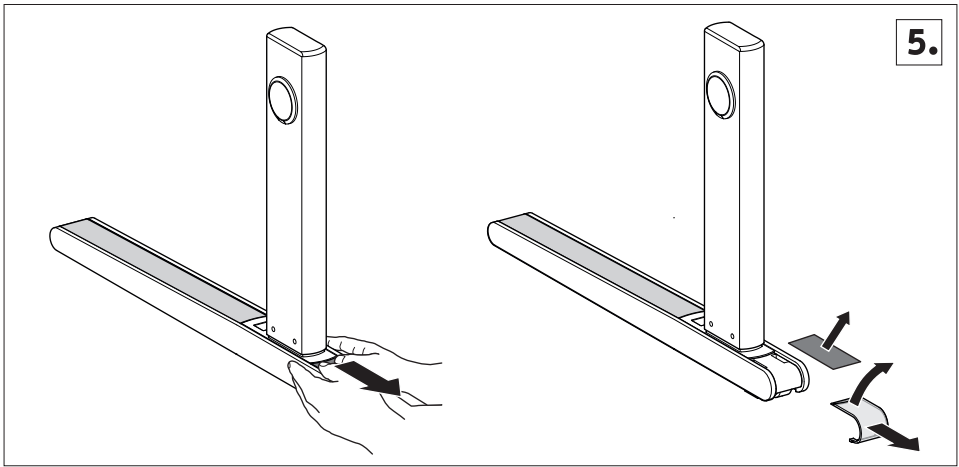

Montage Teil 2
Fußmontage

Assembly Part 2
Attaching the feet

Montage partie 2
Montage des pieds

Montaggio parte 2
Montaggio delle gambe

Montaje Parte 2
Montaje de la pata

Монтаж Часть 2
Монтаж ножек

组装 第2部分
桌腿安装

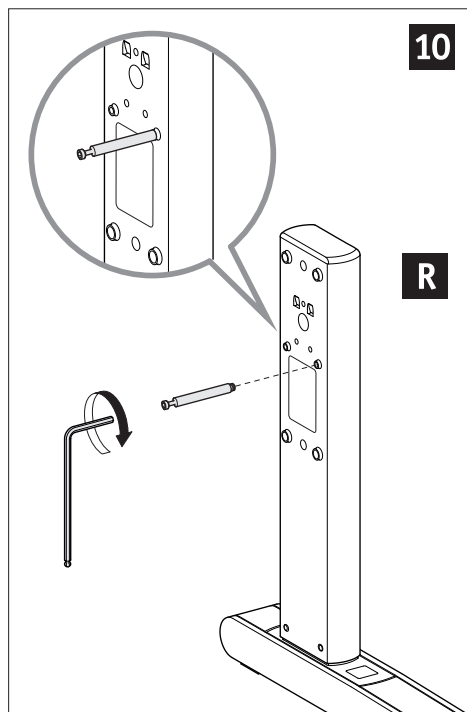
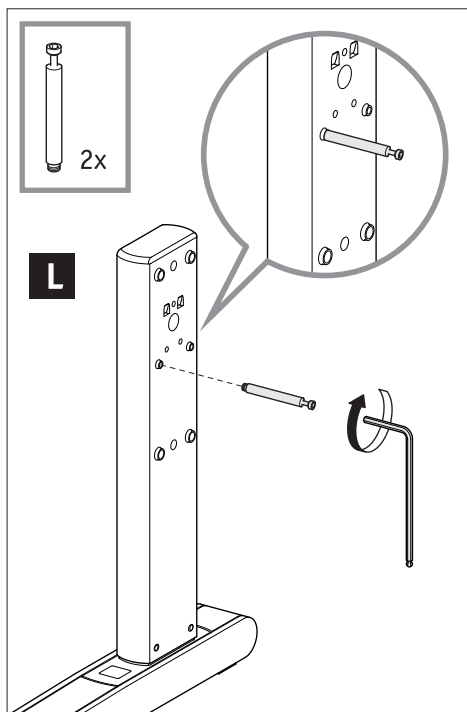
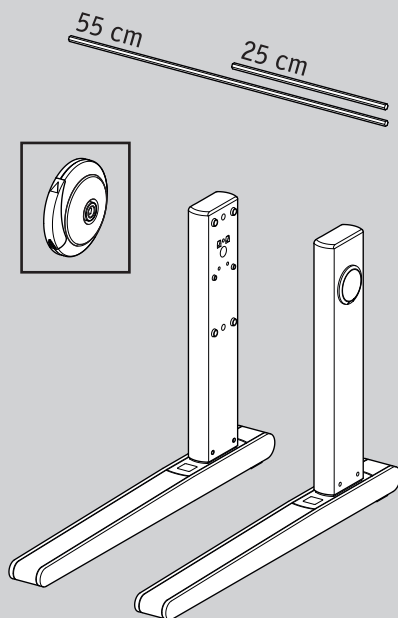

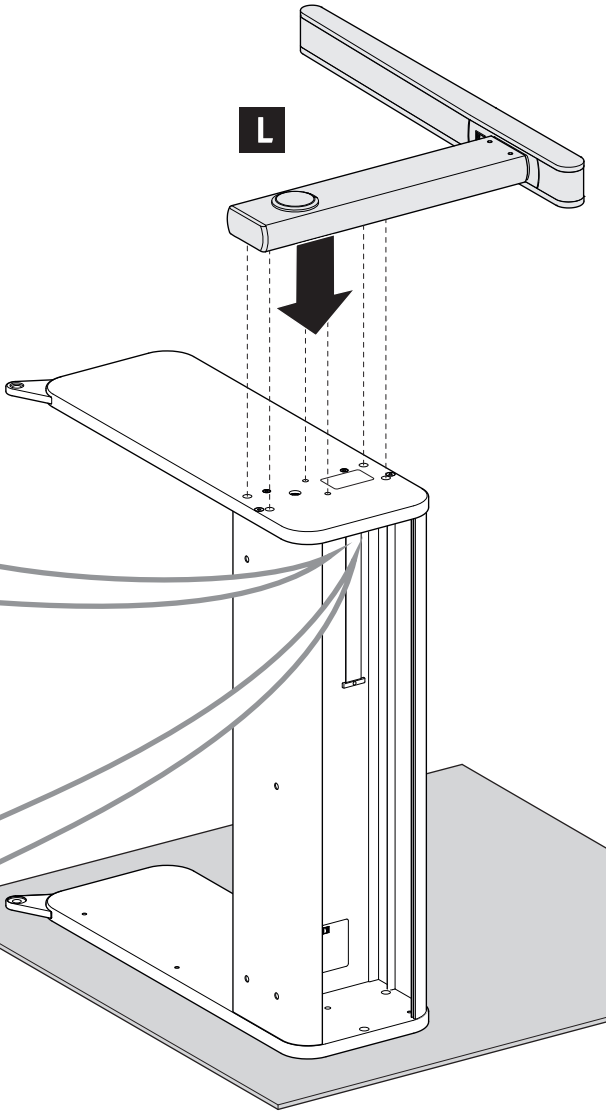
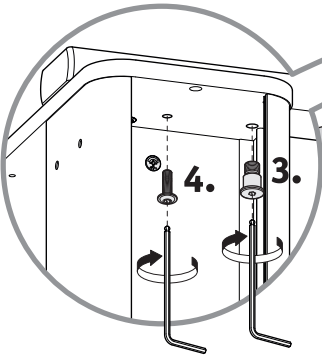
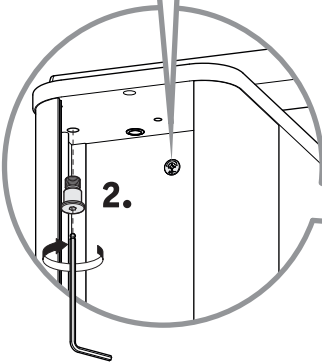
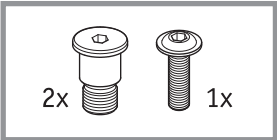

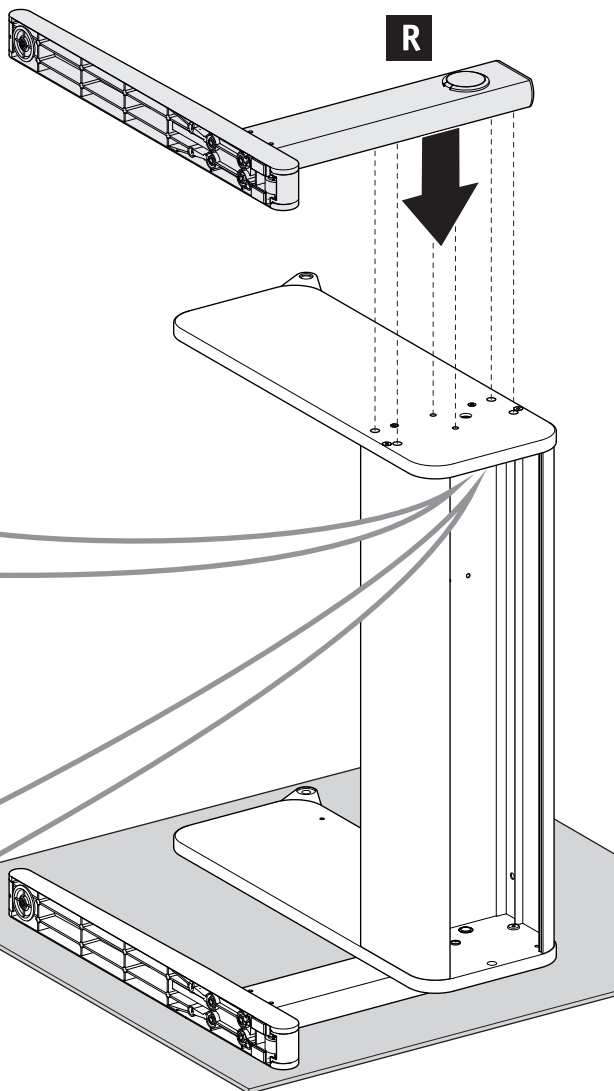
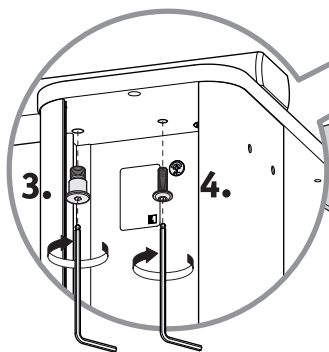
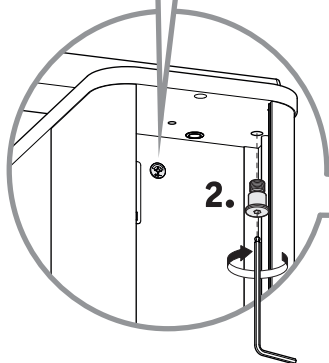
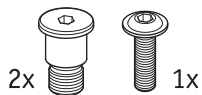

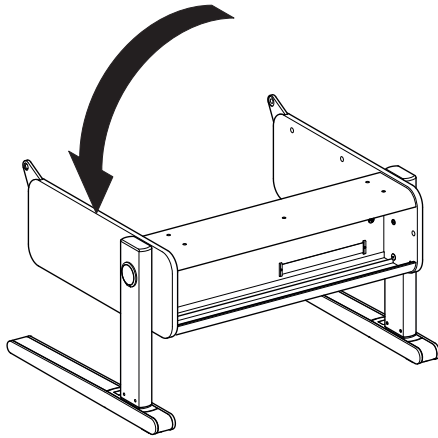

13

1x
55 cm

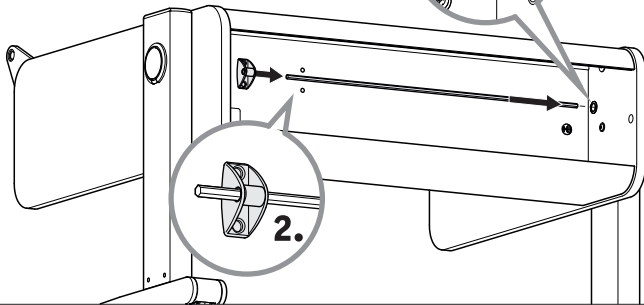

14

1x
25 cm

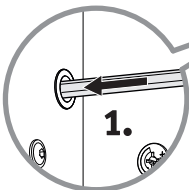
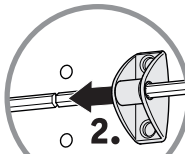

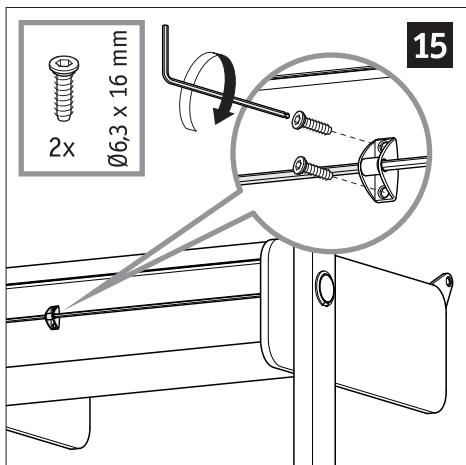

- 15**
- D** **Hinweis:** Für einfachere Montage kann der Tisch jetzt hochgestellt werden, s. Seite 34
 - GB** **Note:** The desk can now be raised for easier installation, see page 34
 - F** **Remarque :** Le bureau peut désormais être surélevé pour faciliter l'installation (page 34)
 - I** **Avvertenza:** La scrivania può ora essere sollevata per più facile installazione (pag. 34)
 - E** **Advertencia:** El escritorio ahora puede ser levantado para facilitar la instalación (página 34)
 - RUS** **Примечание.** Теперь стол можно поднять для упрощения установки, см. стр. 34.
 - CHN** 提示：桌子现在可以升起，便于安装，见第34页。

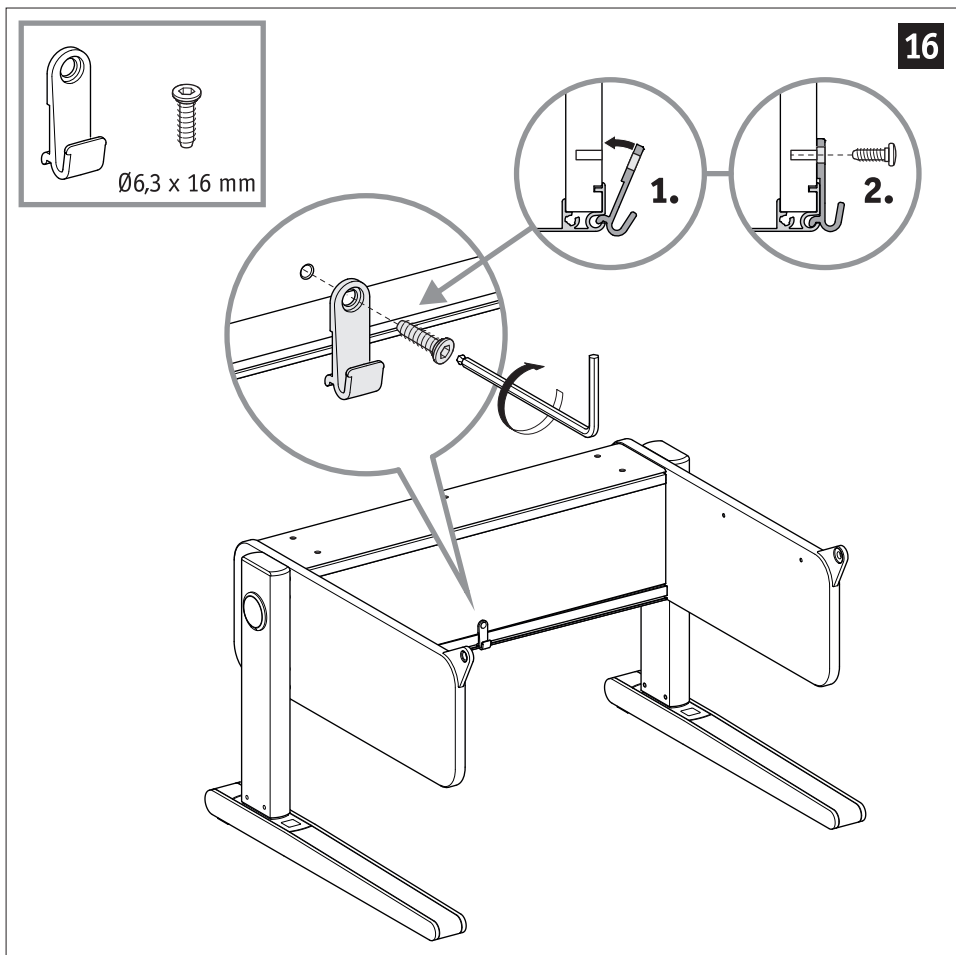

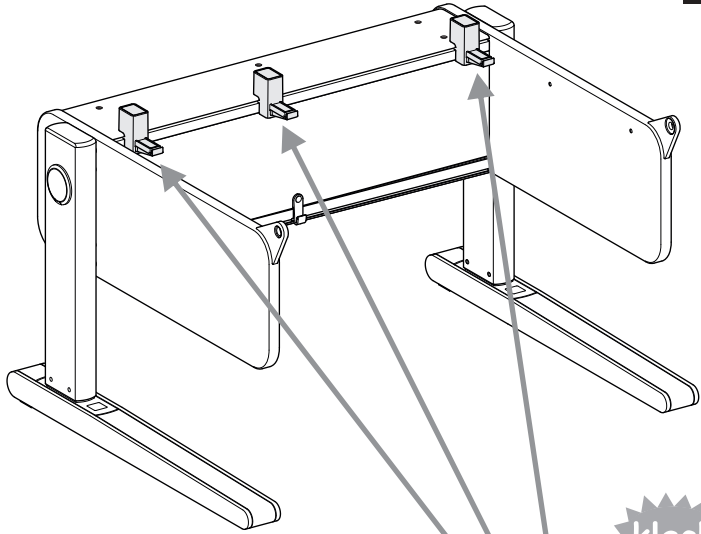
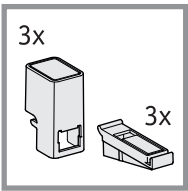

klack

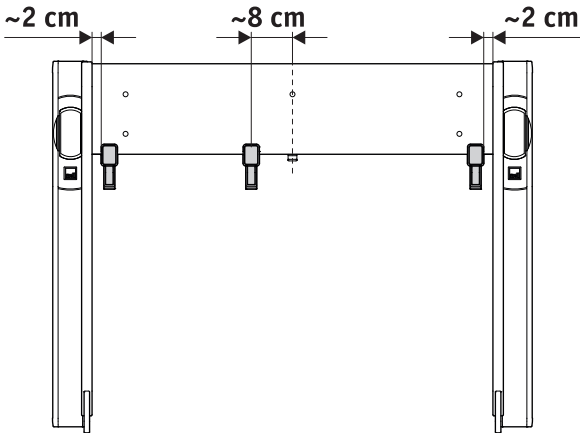
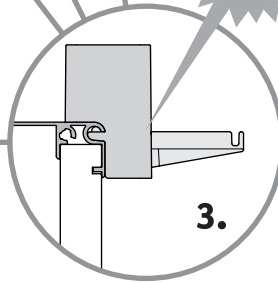
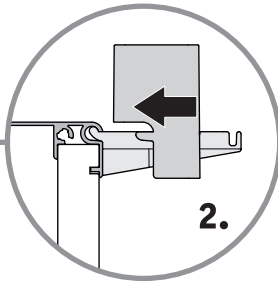
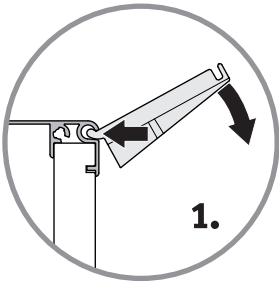

Schublade? → Ja
Drawer? → Yes
Tiroir? → Oui
Cassetto? → Sì
Cajón? → Si
Выдвижной ящик? → да
抽屜? → 是

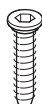
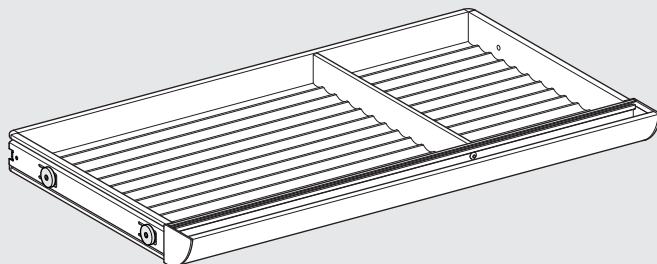
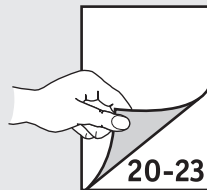

4x

Ø6,3 x 21 mm

Schublade? → Nein
Drawer? → No
Tiroir? → Non
Cassetto? → No
Cajón? → No
Выдвижной ящик? → нет
抽屜? → 不是

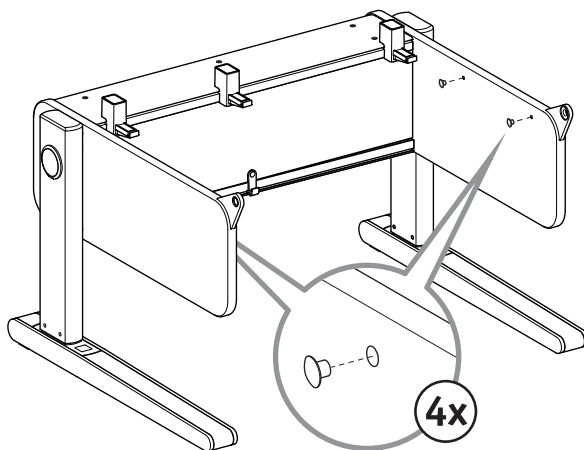
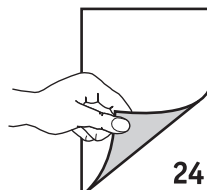

4x

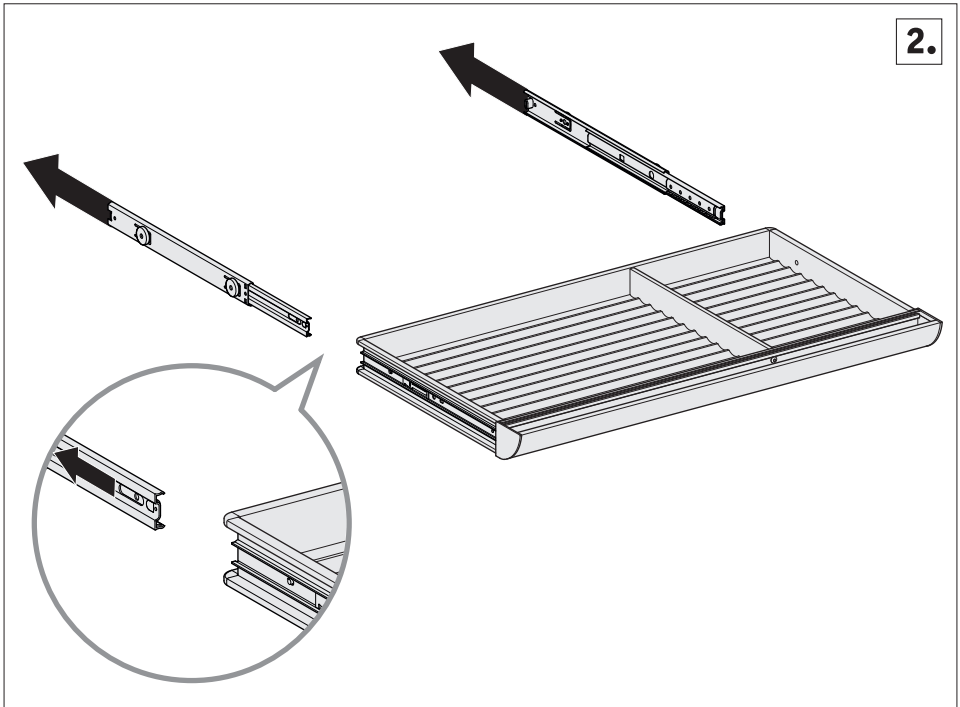
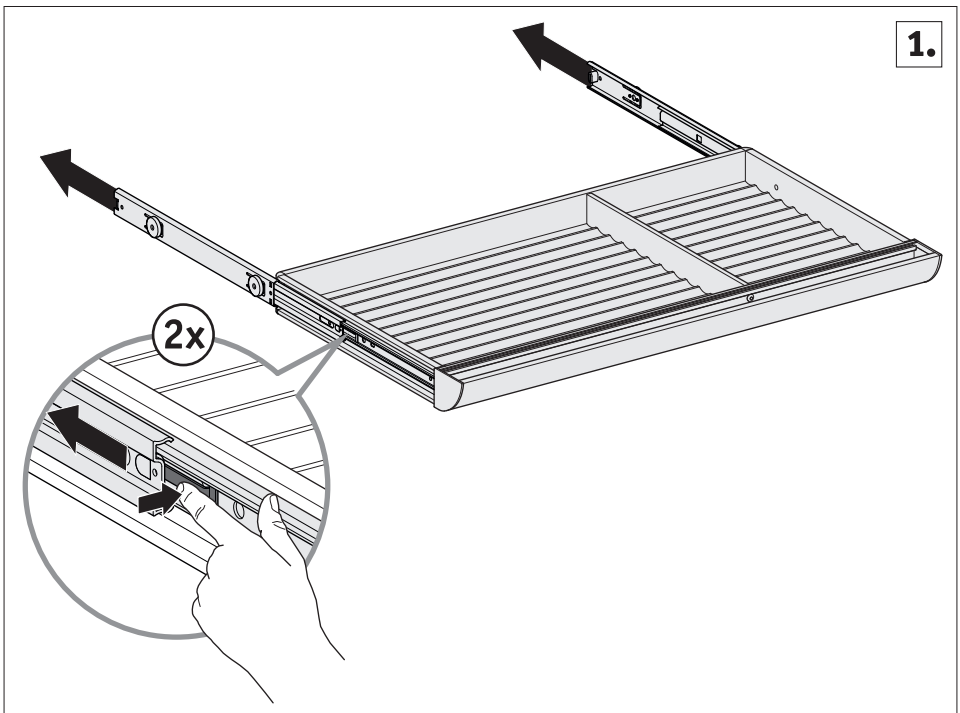

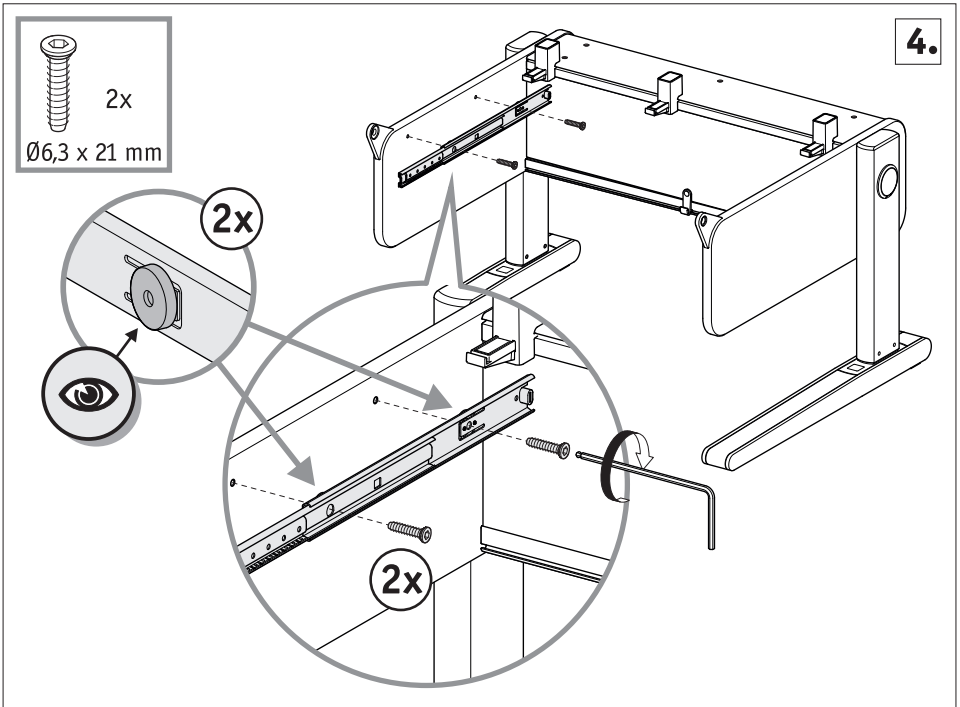
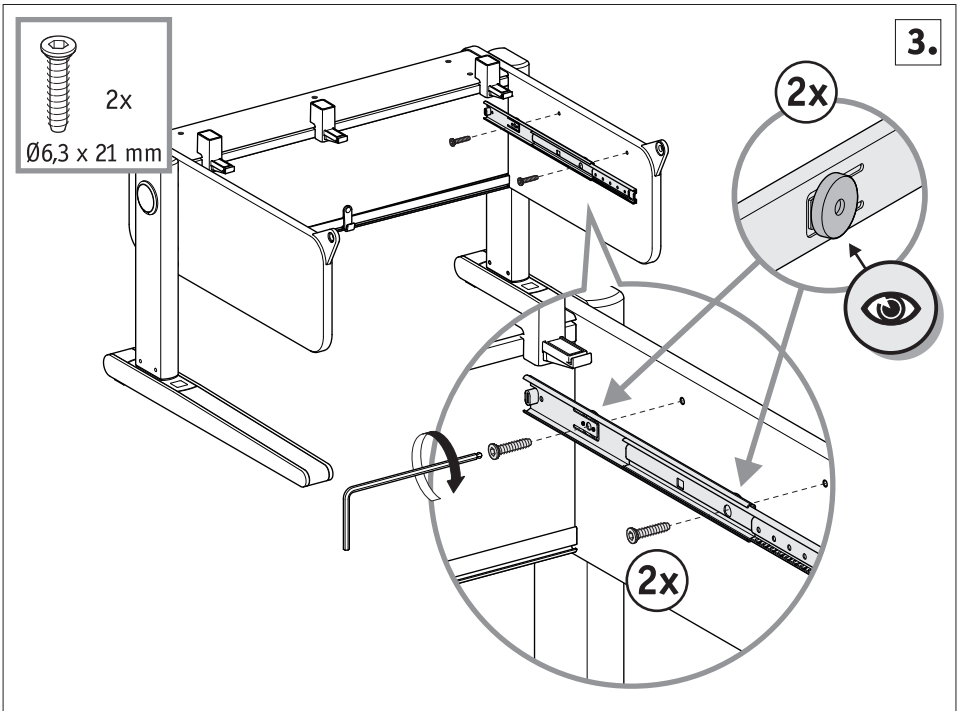



5.

2x

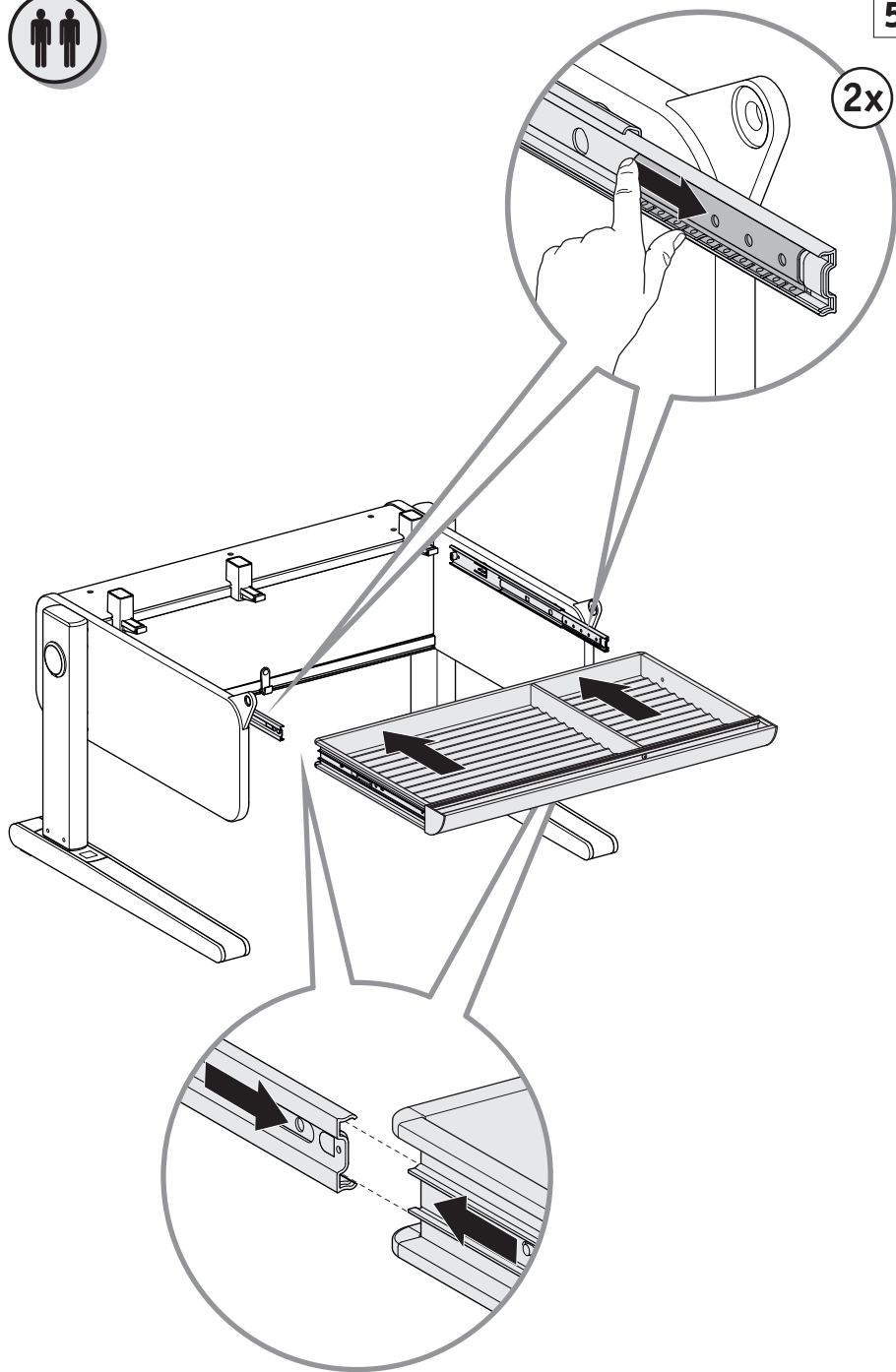

6.

D **Wichtig!** Als erstes die Schublade ganz einschieben.

Bevor Sie weiter montieren prüfen Sie bitte, ob die Schublade fest eingerastet ist, indem Sie diese kräftig bis zum Anschlag öffnen.

GB **Important!** First, slide the drawer in completely.

Before you proceed assembling, please make sure that the drawer is firmly locked in place by opening the drawer all the way to the stop.

F **Important!** Enfoncez tout d'abord le tiroir à fond.

Vérifiez ensuite, avant de continuer le montage, que celui-ci est bien enclenché en l'ouvrant fortement jusqu'à la butée.

I **Importante!** In primo luogo p.f. inserire il cassetto completamente.

Prima di continuare con il montaggio, aprire il cassetto fino al punto di arresto per assicurarsi che sia messo in posizione corretta.

E **¡Importante!** Primero introduzca el cajón completo.

Después, antes de que usted continúe el montaje, evalúe si el cajón engranó firmemente por favor en lo que respecta a usted abra el cajón hasta el tope.

RUS **Важно!** Сначала вставьте ящик в направляющие и задвиньте его.

Прежде чем Вы продолжите монтаж, убедитесь, хорошо ли ящик зафиксирован на направляющих. Для этого выдвиньте его с силой до упора.

CHN **重要!** 首先把抽屉完全推进去, 再把抽屉打开到头, 确认抽屉已经卡紧, 然后再继续组装。

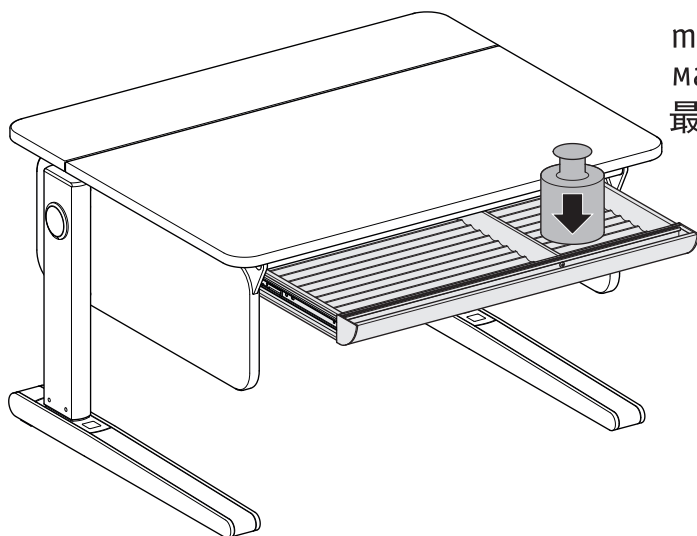

max. 6 kg
макс. 6 кг
最大6公斤

18

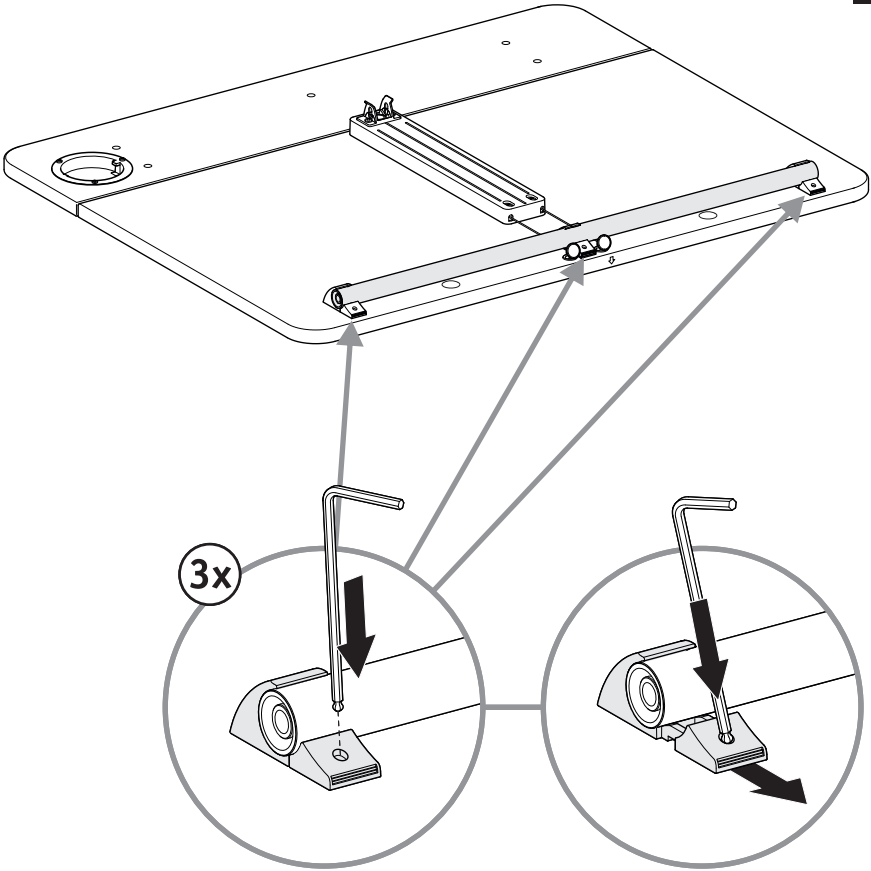

19

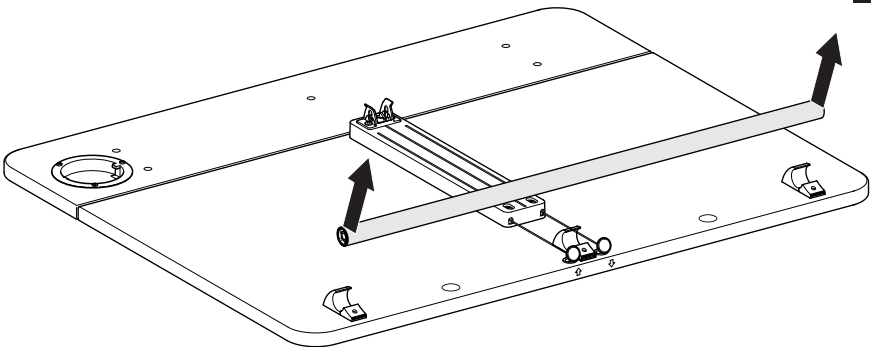

20

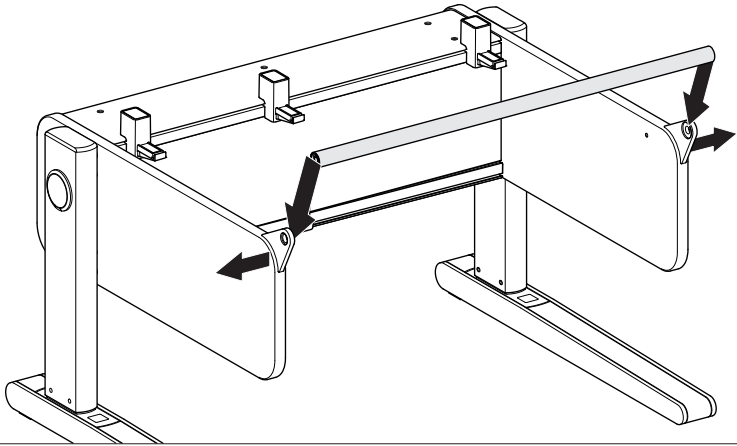

21

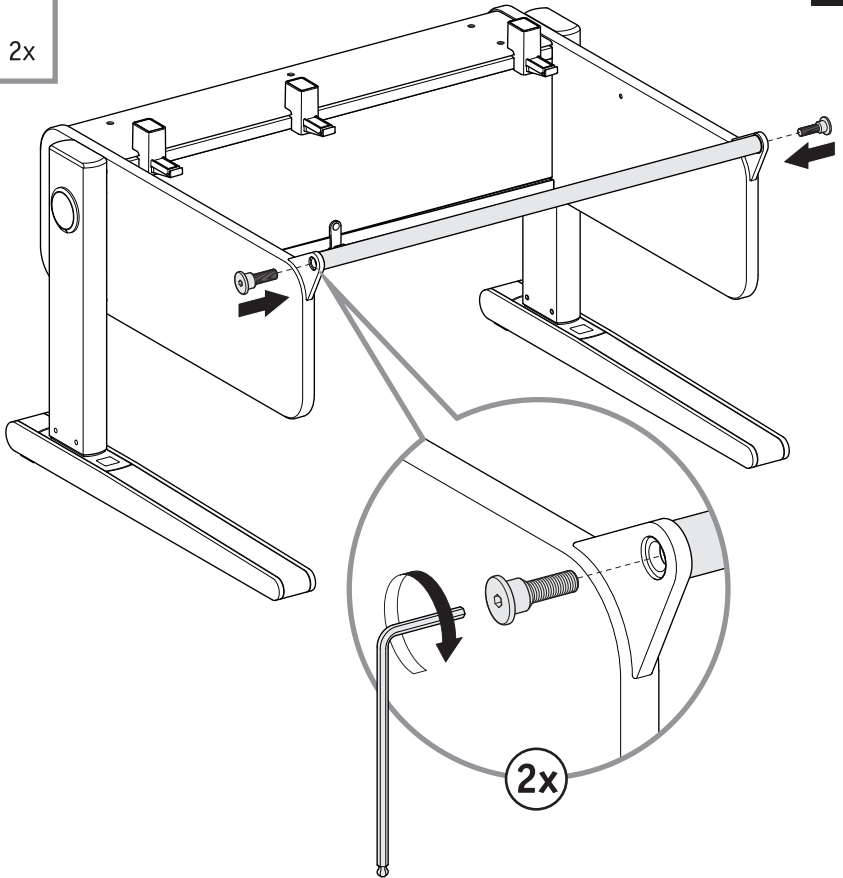
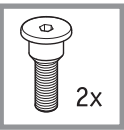



22

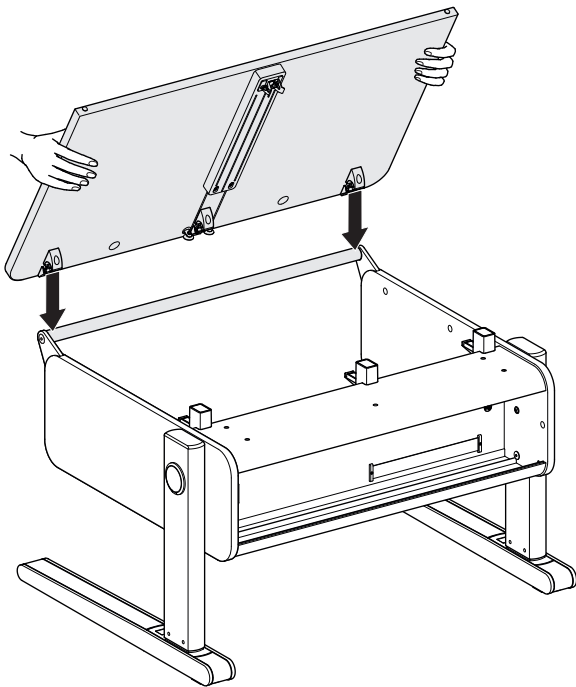

23

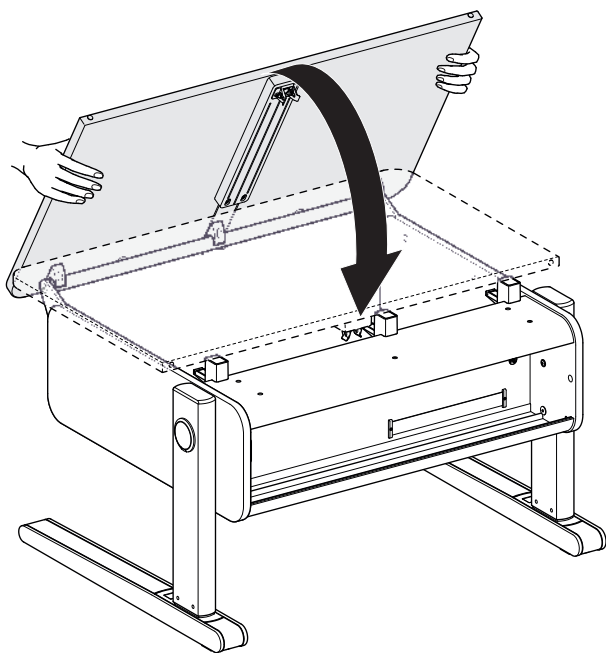

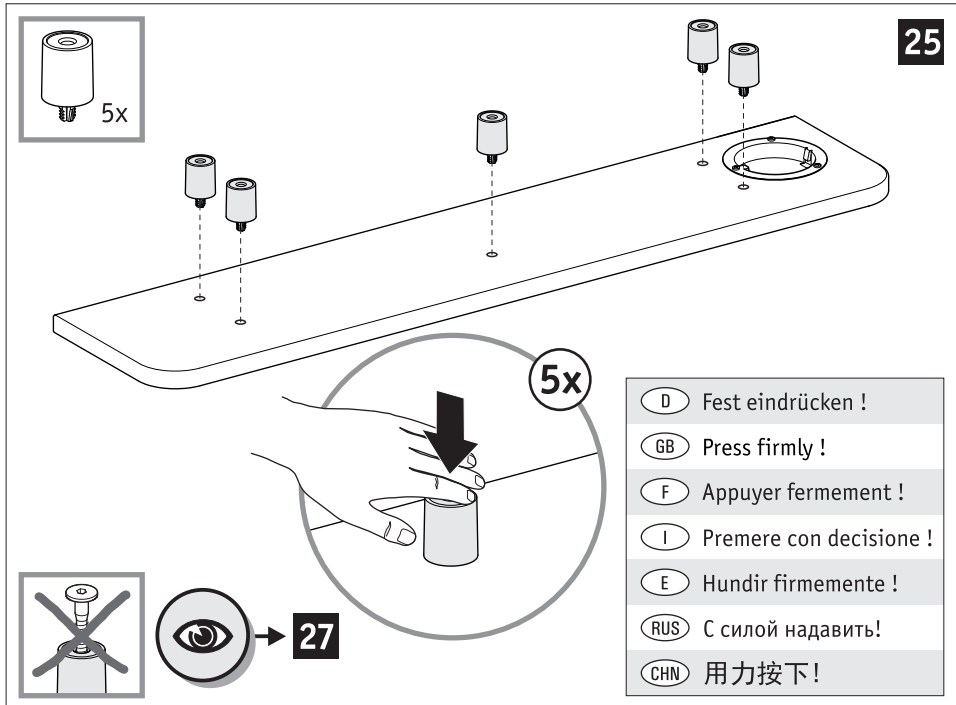
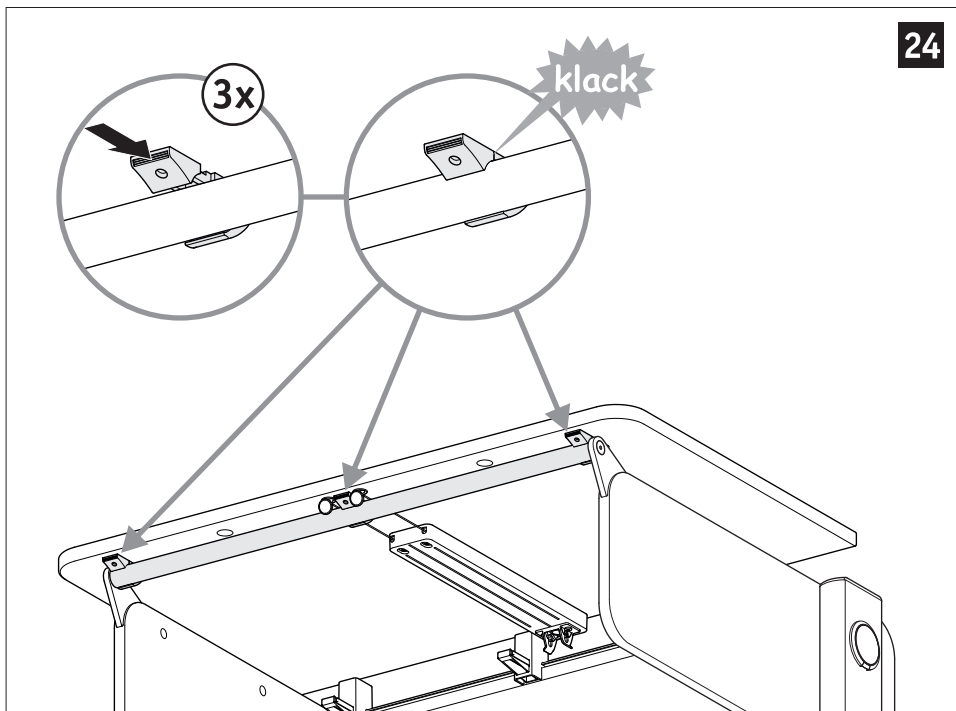

26

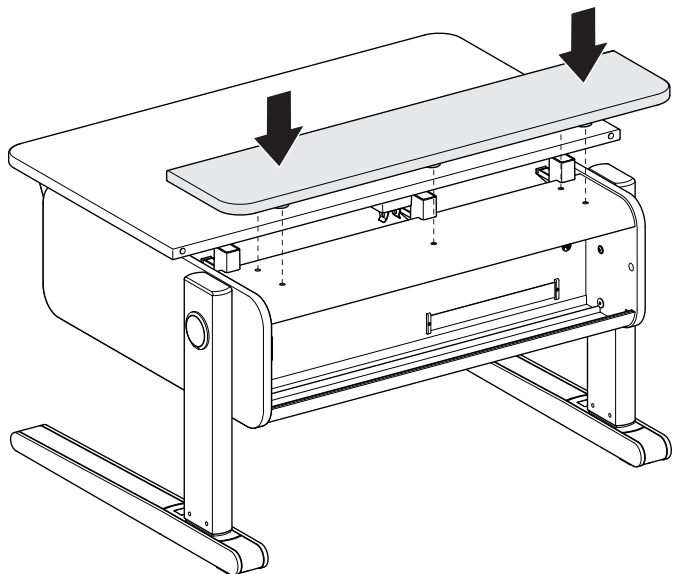

27

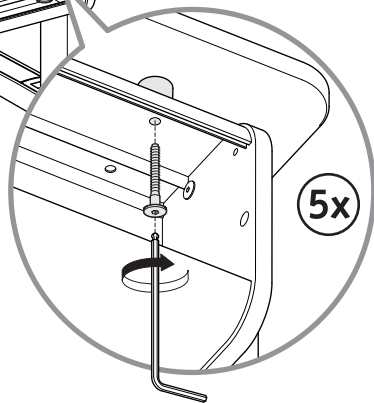
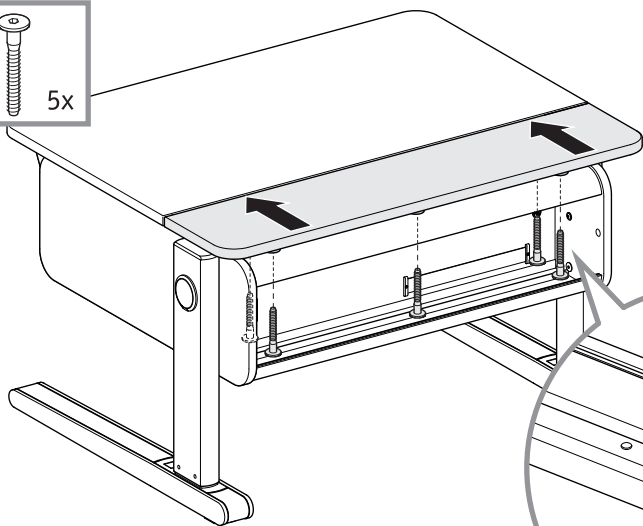
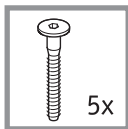

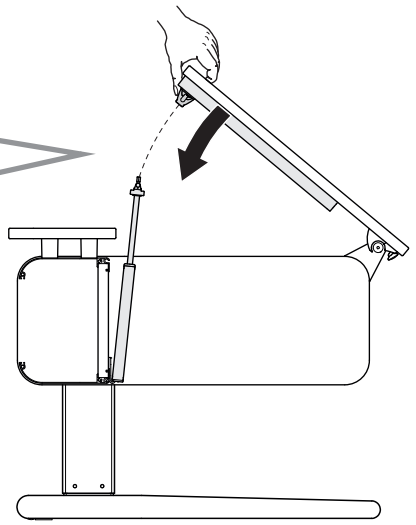
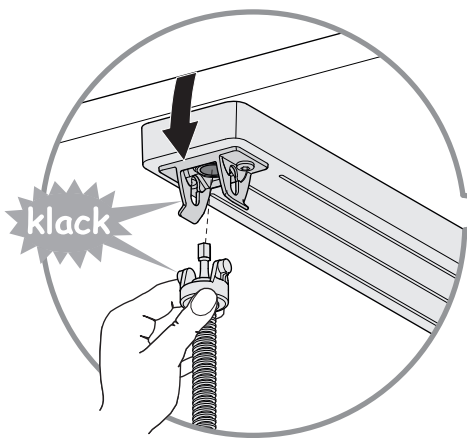
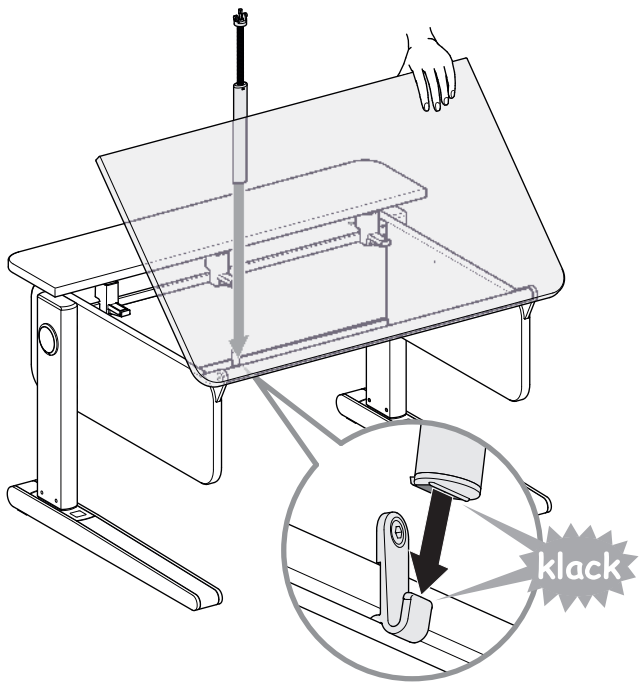
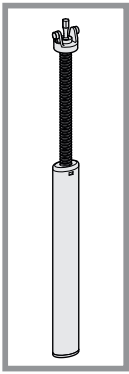

30

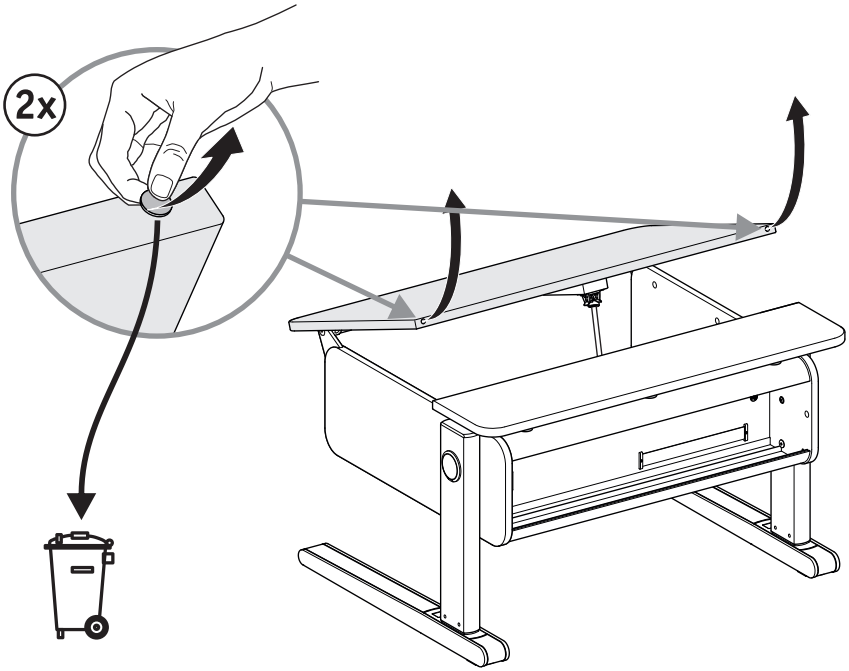

31

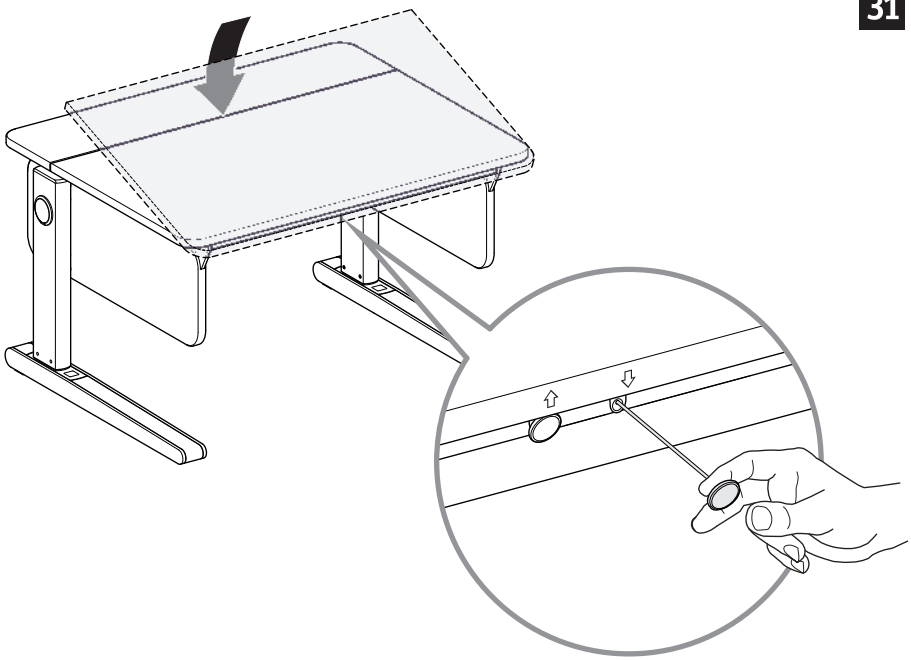

Bedienungshinweise
Instructions for use
Mode d'emploi
Istruzioni per l'uso

Indicaciones de manejo
Указания по эксплуатации
使用提示

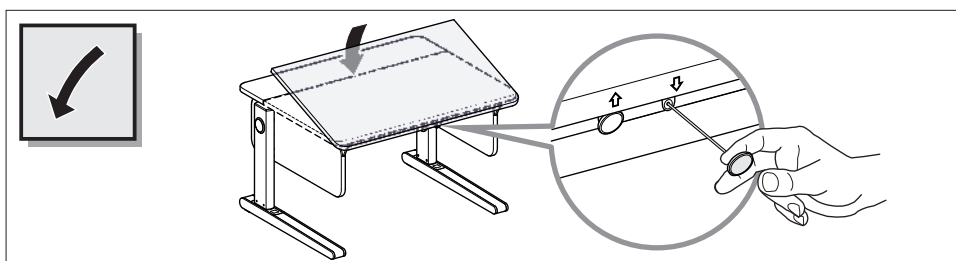
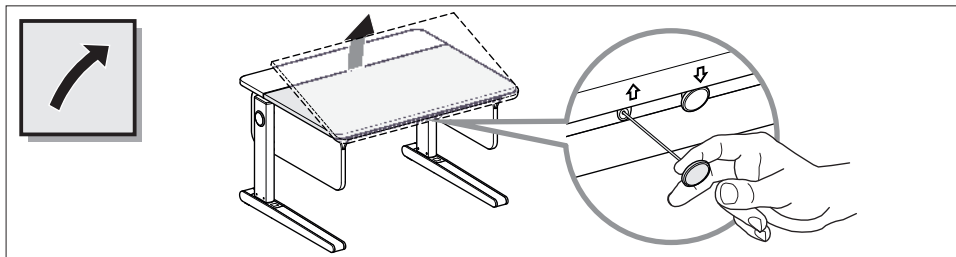

D

Hinweis: Wenn eine Endposition (Tischplatte oben bzw. unten) erreicht ist, bitte nicht mehr weiterziehen! Ein danach einsetzendes, ratschendes Geräusch ist normal und wird durch die Sicherheitskupplung erzeugt, die den Schrägstellmechanismus vor Beschädigung schützt.

GB

Note: An end position (top or bottom) is reached, please do not pull any further! A ratchet sound after that is normal and is generated by the safety clutch which protects the tilt mechanism from damage.

F

Remarque : Lorsque le plateau de la table a atteint sa hauteur maximale ou minimale, veuillez ne pas appuyer davantage ! Un bruit de cliquet se fait alors entendre. Il est tout à fait normal et est généré par le raccord de sécurité qui prévient les dommages du mécanisme d'inclinaison.

I

Avvertenza: Quando viene raggiunta una posizione finale (in alto o in basso), non tirarle oltre! Un suono a cricchetto dopo quello è normale e viene generato dalla frizione di sicurezza che protegge il meccanismo di inclinazione da eventuali danni.

E

Advertencia: Cuando se ha alcanzado una posición final (superficie del escritorio hacia arriba o hacia abajo), ¡no siga adelante! Un ruido de trinquete es normal y es generado por el embrague de seguridad que protege el mecanismo de inclinación contra daños.

RUS

Примечание. Когда достигнуто конечное положение (верхняя или нижняя часть), пожалуйста, не тяните дальше! Звук трещотки после этого нормальный и генерируется предохранительной муфтой, которая защищает механизм наклона от повреждений.

CHN

提示:
如果达到了极限位置（最高或最低），请勿继续拉动！若继续拉动，将会产生锯齿磨损的声响，通常是防止机械装置损坏的安全装置产生的。

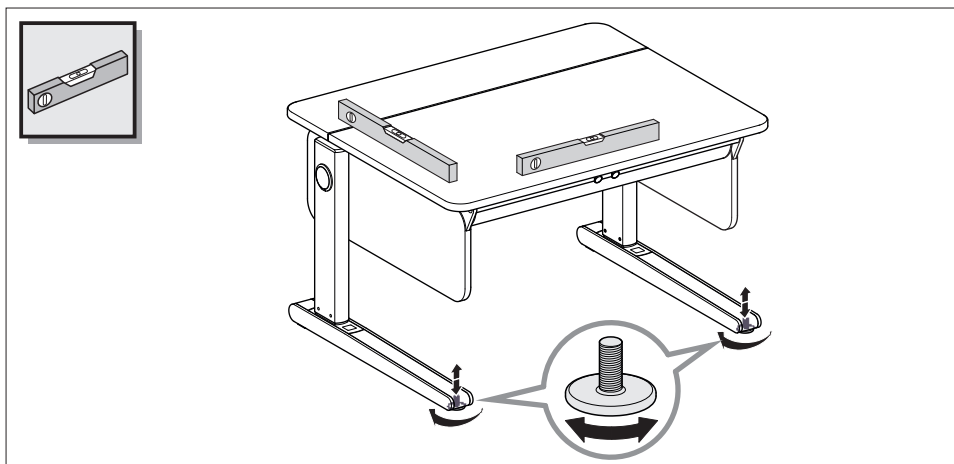
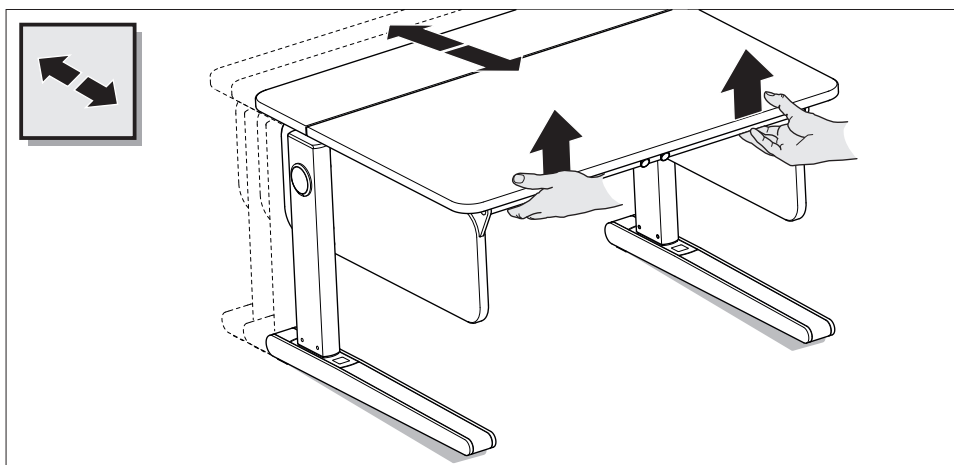

- D** Ein ungleichmäßiger Spalt an der Tischplatte lässt sich mit Hilfe der Verstell-Teller ausgleichen.
- GB** An uneven gap at the table top can be compensated by using the adjusting plate.
- F** Une fente de plateau inégale peut être compensée à l'aide des pieds réglables.
- I** Un divario irregolare da piano della tavola può essere compensato utilizzando la piastra di regolazione.
- E** Se puede nivelar una rendija irregular en la tabla de la mesa con los pies ajustables.
- RUS** Неравномерный зазор на столешнице можно выровнять с помощью выравнителей пола.
- CHN** 如果出现桌面不平整，可通过桌腿的调节旋钮作调整。

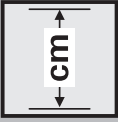

Höhenverstellung
Height adjustment
Réglage en hauteur
Regolazione in altezza

Ajuste de altura
Регулировка по высоте
高度调整

Comfort

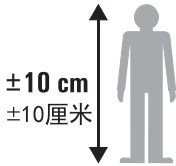

119 cm	~ 53 cm	~ 28 - 32 cm
127 cm	~ 56 cm	~ 30 - 34 cm
135 cm	~ 59 cm	~ 32 - 37 cm
143 cm	~ 63 cm	~ 36 - 39 cm
151 cm	~ 66 cm	~ 38 - 42 cm
159 cm	~ 69 cm	~ 40 - 44 cm
167 cm	~ 72 cm	~ 42 - 46 cm
175 cm	~ 75 cm	~ 44 - 48 cm
183 cm	~ 79 cm	~ 47 - 51 cm
191 cm	~ 82 cm	~ 49 - 54 cm

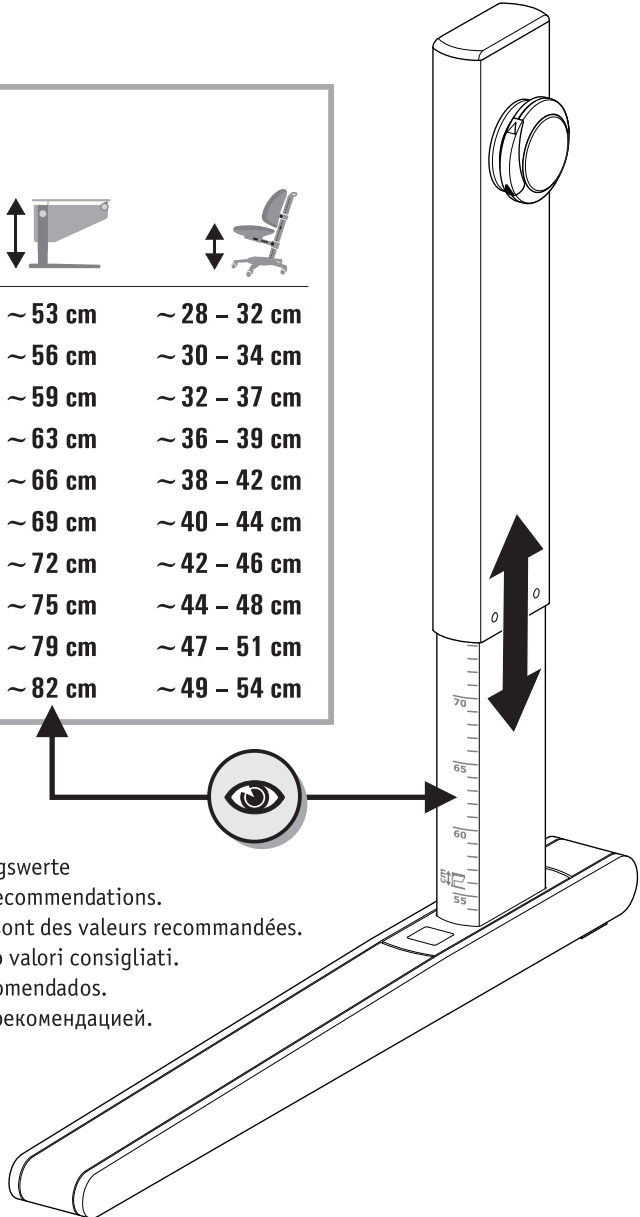

Angaben sind Empfehlungswerte
Figures shown here are recommendations.
Les indications fournies sont des valeurs recommandées.
Queste informazioni sono valori consigliati.
Los datos son valores recomendados.
Данные являются лишь рекомендацией.
数据为建议值

Tisch hochstellen
Raise desk
Relever la table
Sollevare il tavolo

Elevar la mesa
Поднять стол
调高桌子

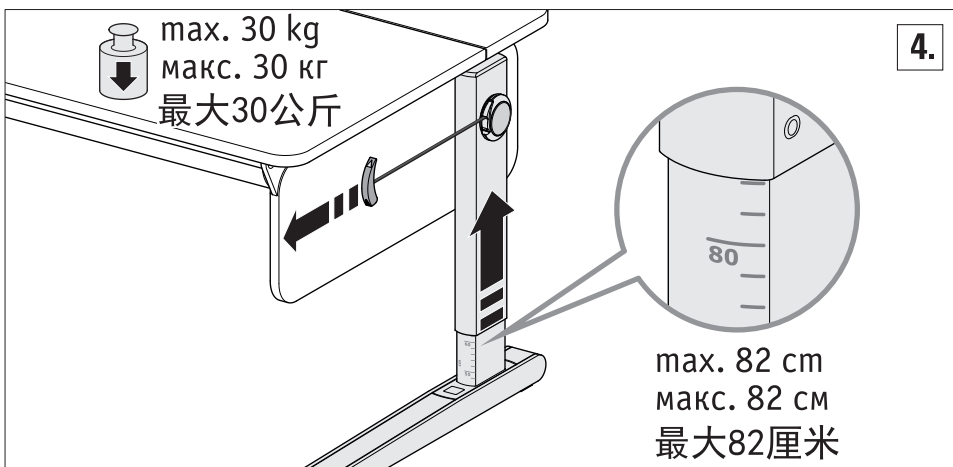
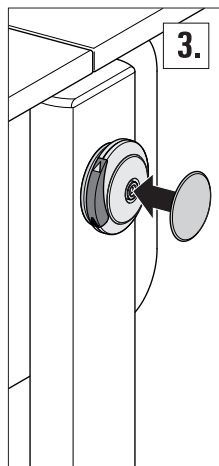
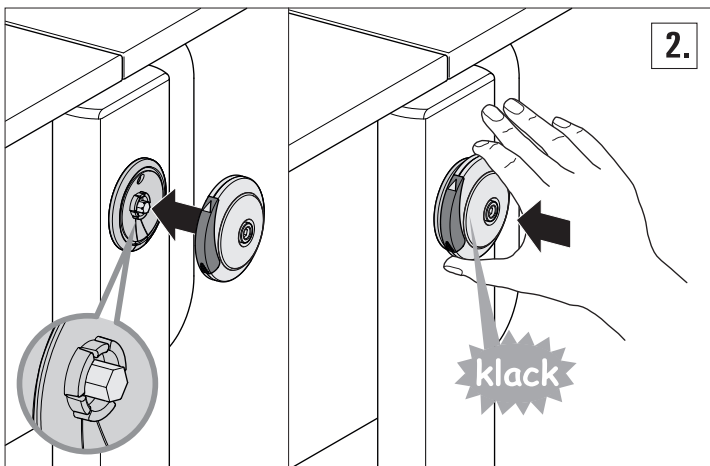
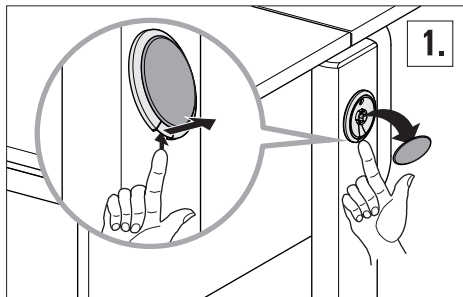
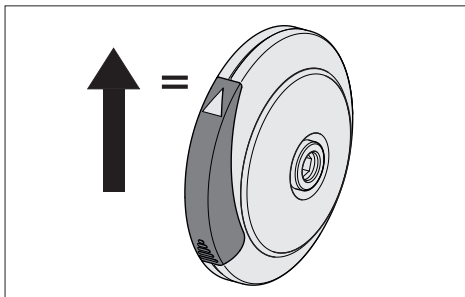

Tisch absenken
Lower desk
Abaisser la table
Abbassare il tavolo

Bajar la mesa
Опустить стол
降下桌子

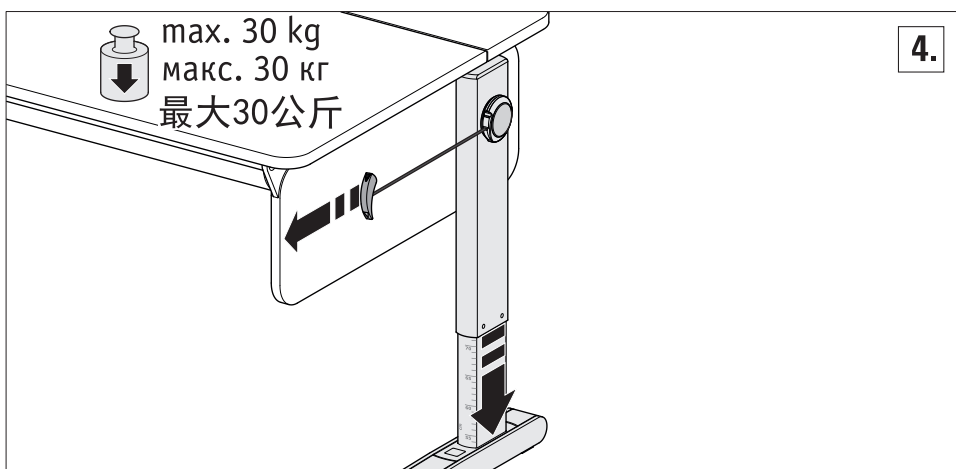
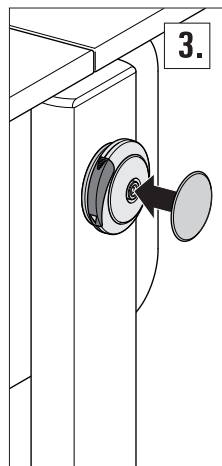
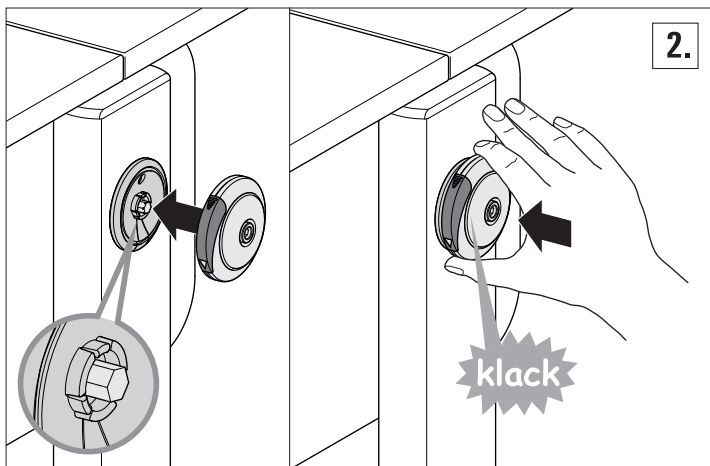
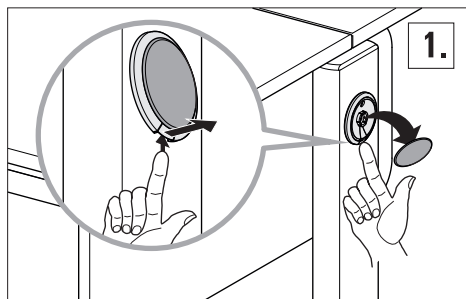
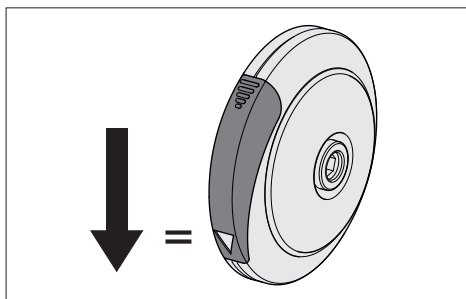



Farbwechsel
Color change
Changement de couleur
Cambiare i colori

Cambio de color
Замена цветных элементов
换色

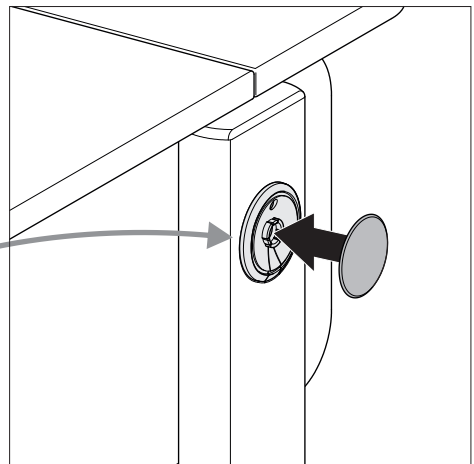
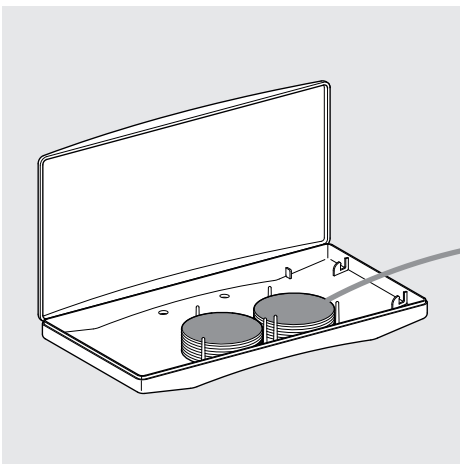
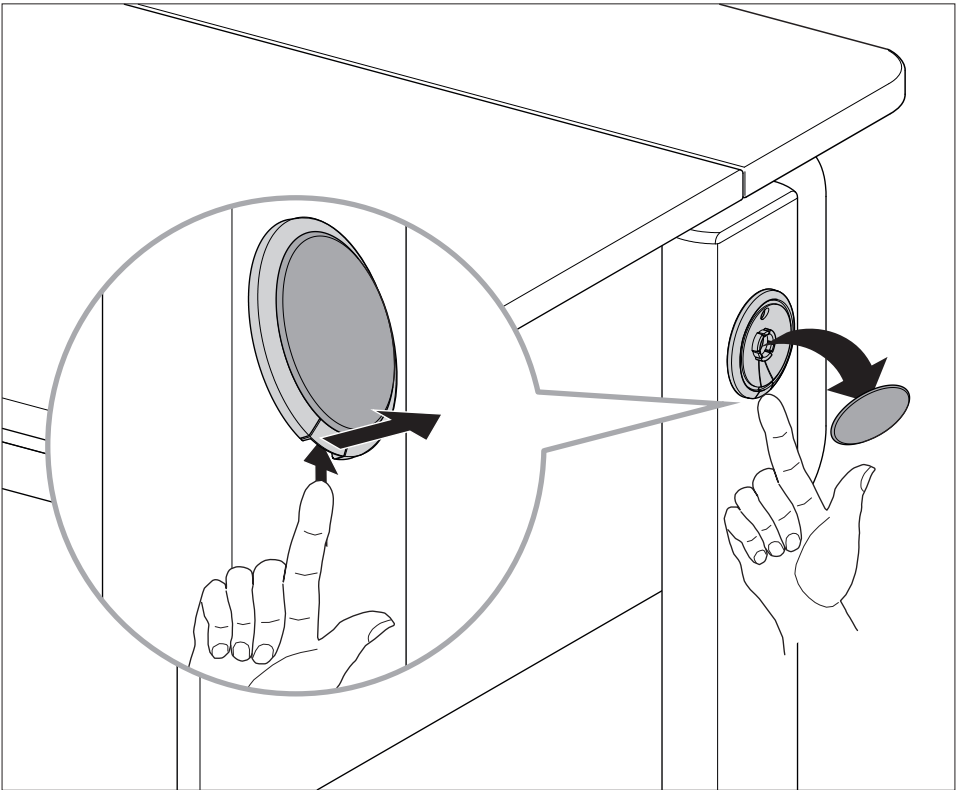

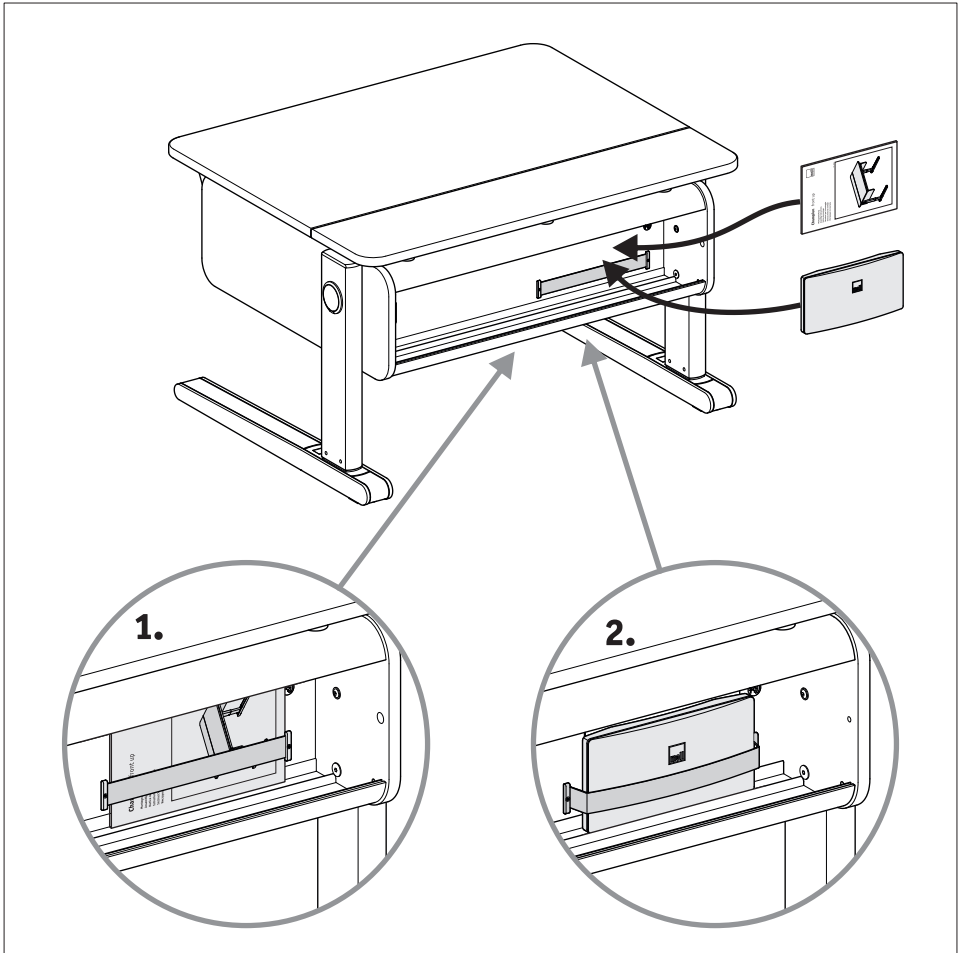
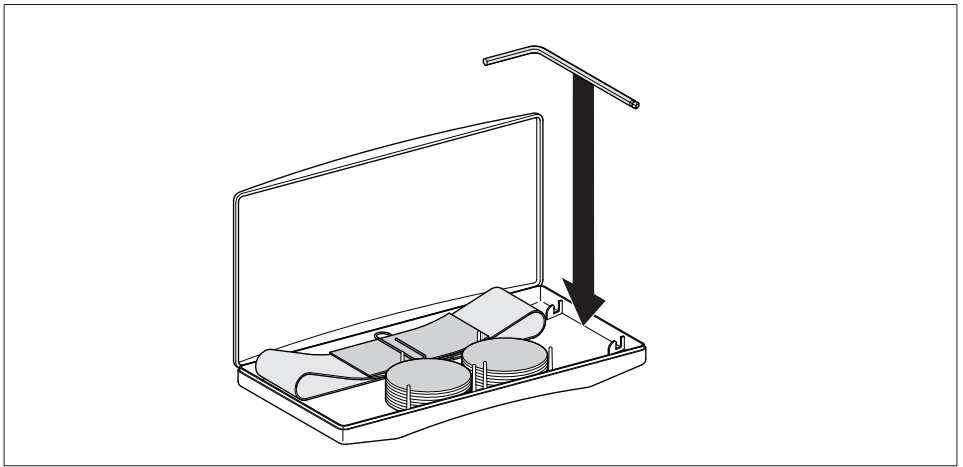

Ersatzteil
Spare part
Pièce de rechange
Pezzo di ricambio

Pieza de recambio
Запасная часть
备用件

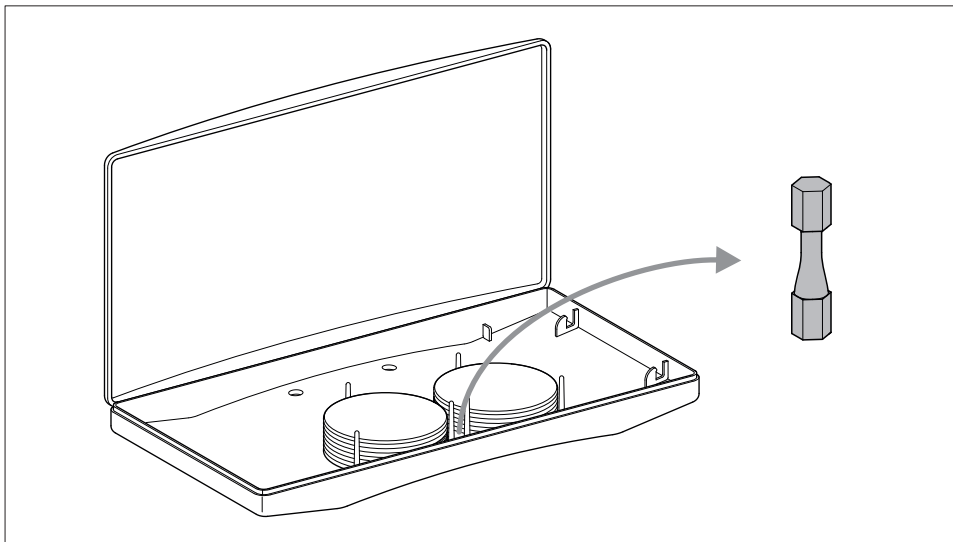

- (D) Der Überlastschutz kann bei Bedarf ganz leicht ersetzt werden.
- (GB) The overload protection can be easily replaced if necessary.
- (F) La protection contre les surcharges peut être facilement remplacée si nécessaire.
- (I) La protezione di sovraccarico può essere facilmente sostituito se necessario.
- (E) La protección de sobrecarga puede ser fácilmente sustituido si es necesario.
- (RUS) В случае необходимости защита от перегрузки может быть легко заменена.
- (CHN) 需要时，超重保护装置可轻易更换。

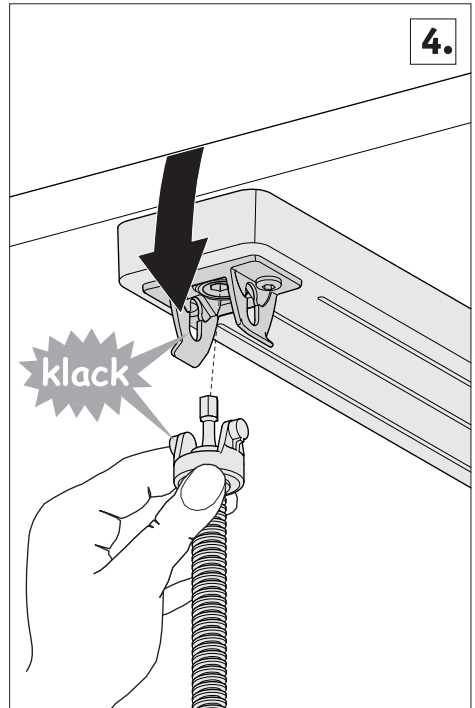
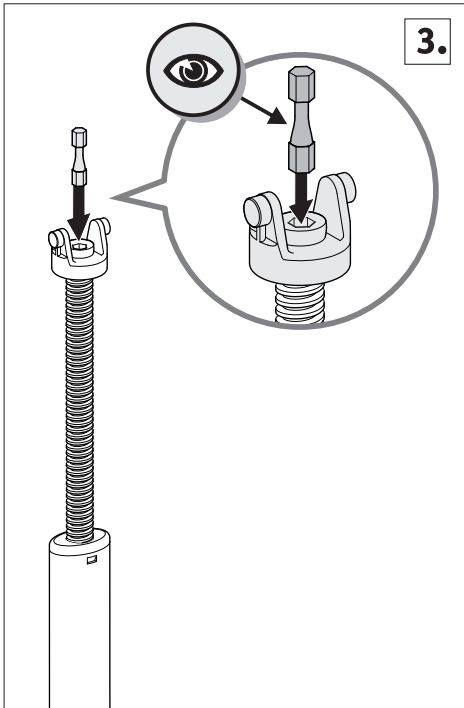
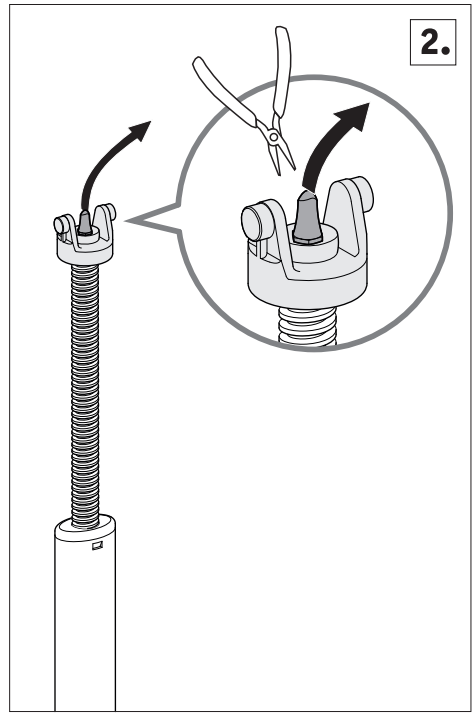
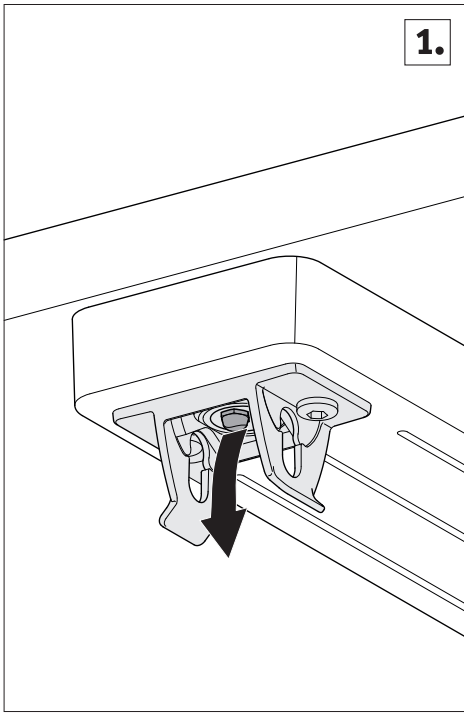

Zubehör
Accessories
Accessoires
Accessori

Accesorios
Аксессуары
配件

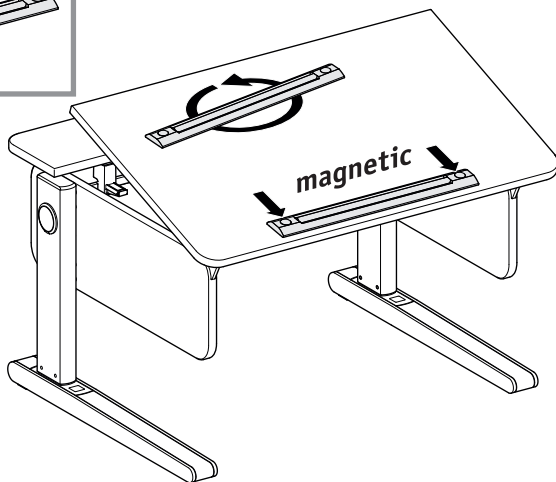
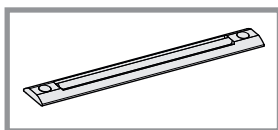

magnetisch
magnetic
magnétique
magnética
magnético
магнитная
磁吸尺

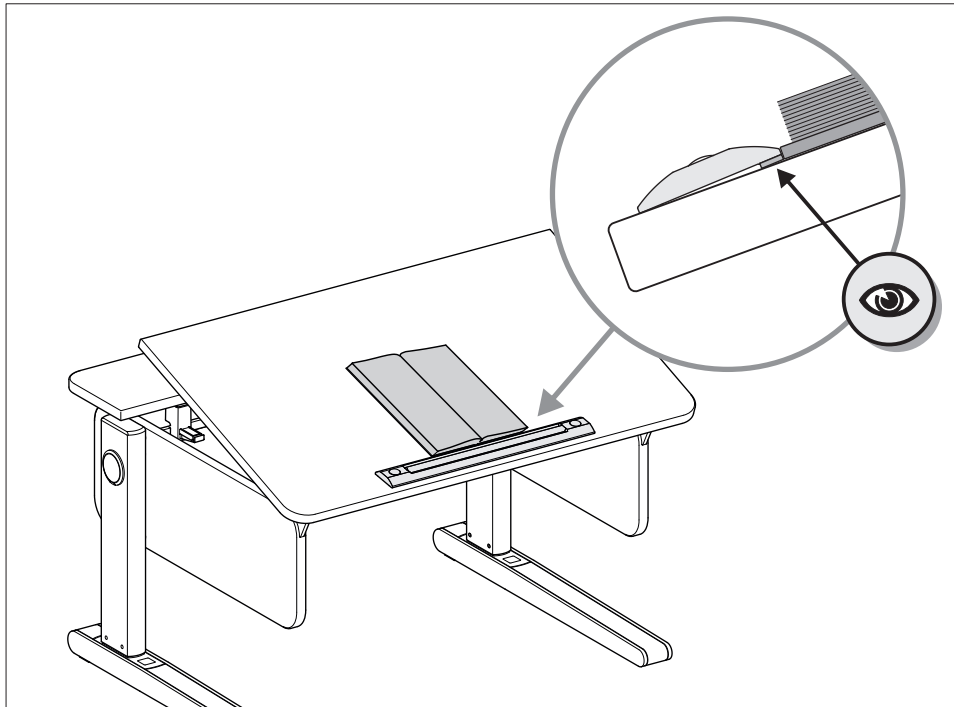

Montageanleitung Buchstütze
Assembly instructions Book holder
Notice de montage Repose-livre
Istruzioni per il montaggio Leggio per libri
Instrucciones de montaje Sujetalibros
Инструкция по монтажу Подставка для книг
书挡组装说明

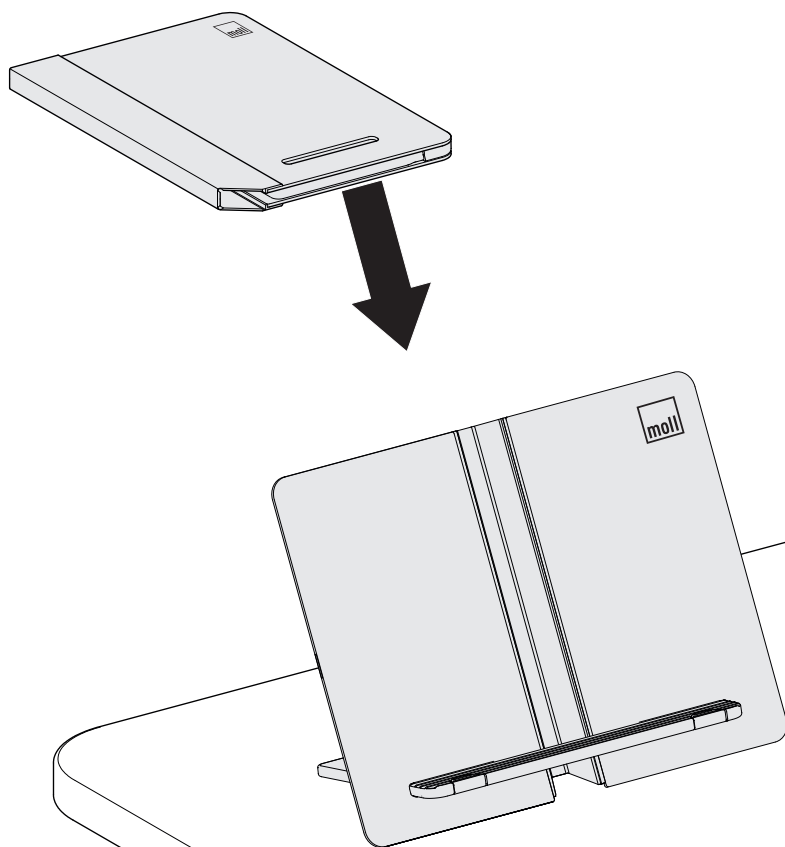

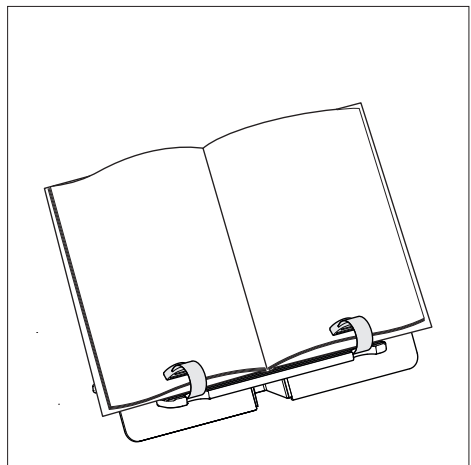
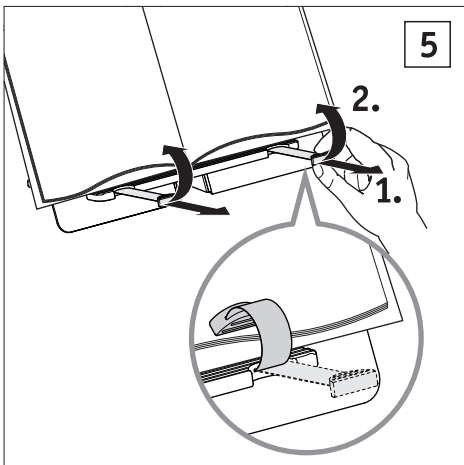
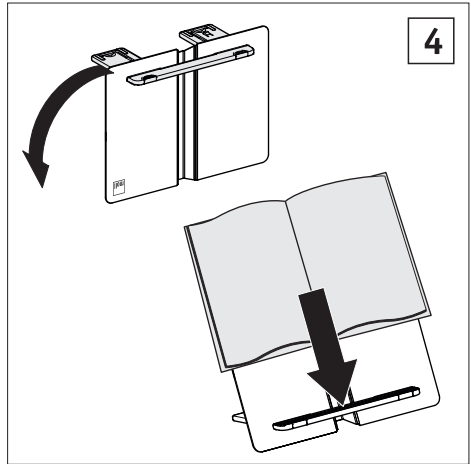
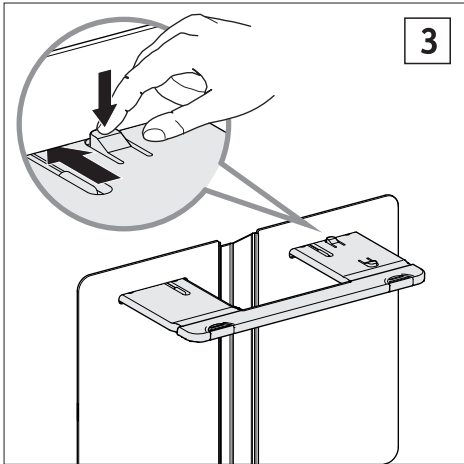
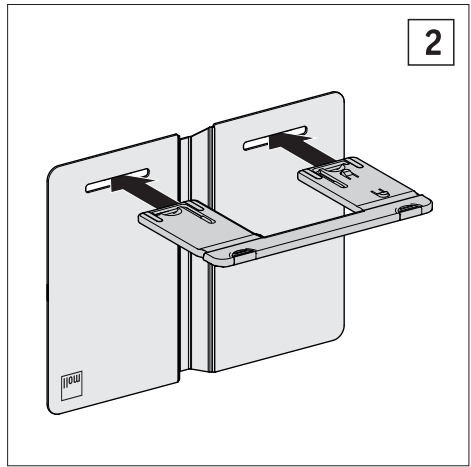
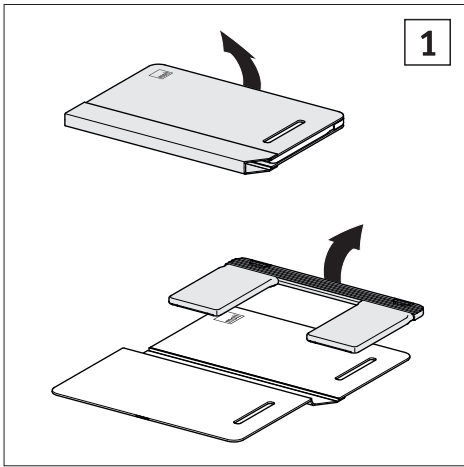

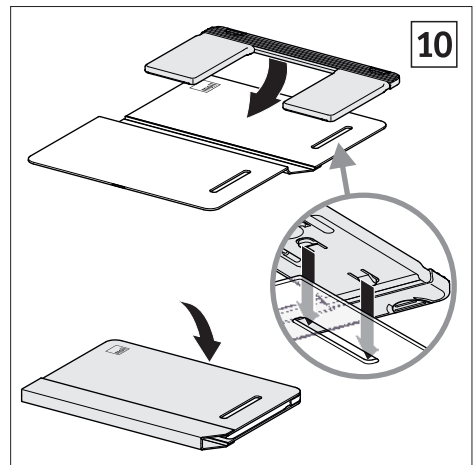
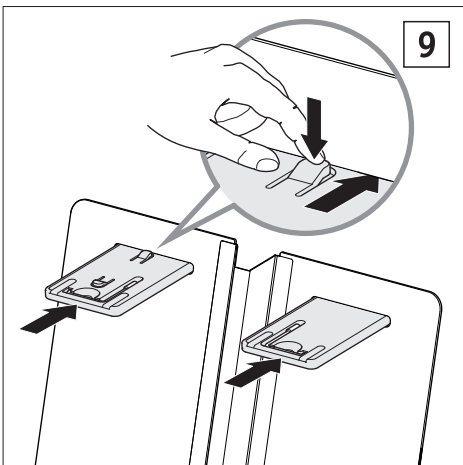
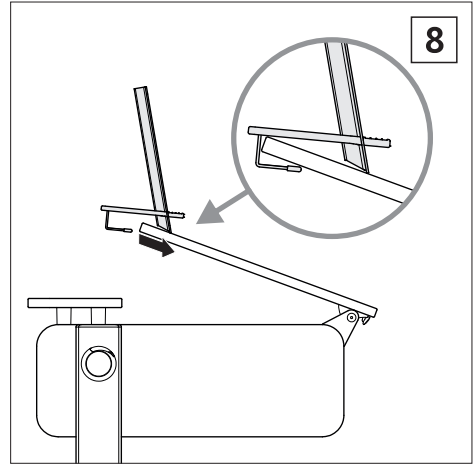
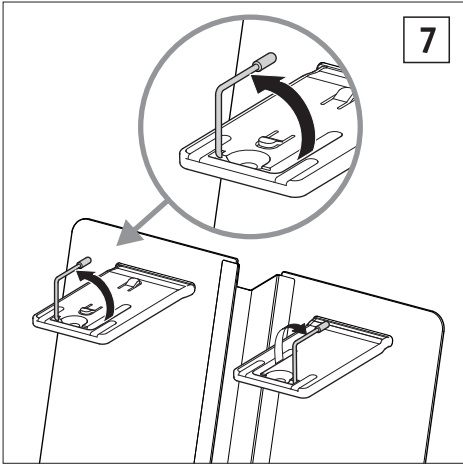
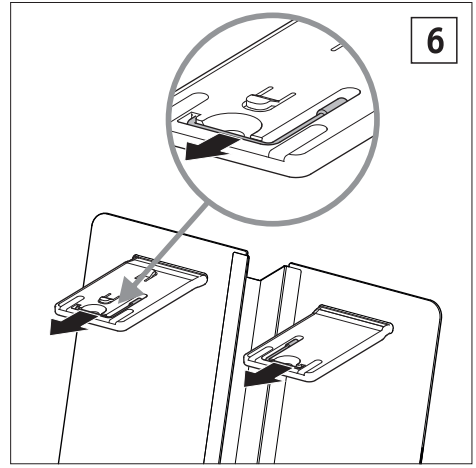
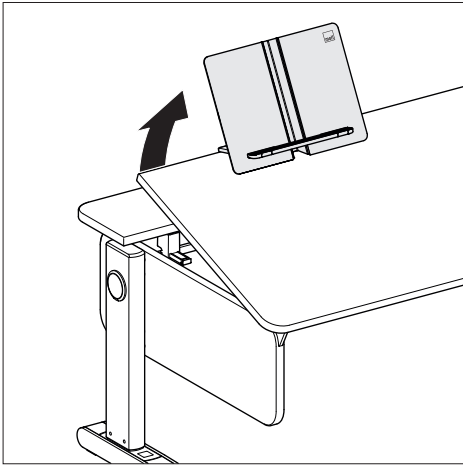

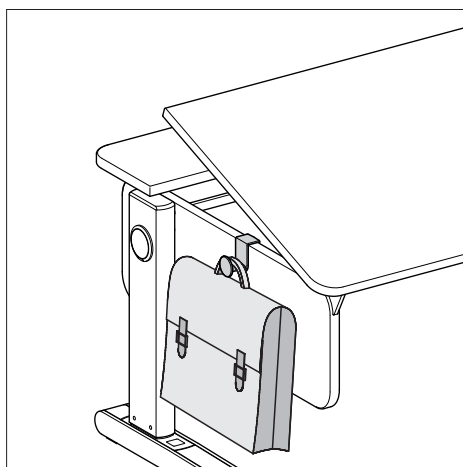
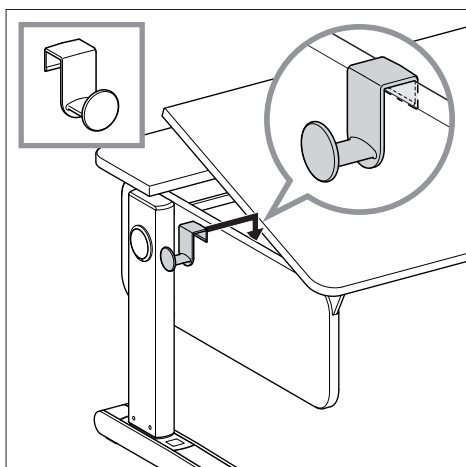

Info
Information
Infos
Informazioni

Información
Информация
信息

D Dieser Tisch ist für das Nachrüsten mit einer Qi-Ladestation für das kabellose Laden elektronischer Geräte vorbereitet. Ausführliche Informationen dazu finden Sie auf unserer Website oder bekommen diese bei Ihrem Fachhändler.



GB This table can be upgraded with a Qi charger for wireless charging of electronic devices. Detailed information can be found on our website or can be obtained from your dealer.

F Cette table est prévue pour être équipée ultérieurement d'une station de charge Qi destinée au chargement sans fil d'appareils électroniques. Pour de plus amples informations à ce sujet, veuillez consulter notre site Web ou votre revendeur.

I Questo tavolo è predisposto per l'ammodernamento con una stazione di ricarica Qi per la carica senza fili degli apparecchi elettronici. Per maggiori informazioni al riguardo consultare il nostro sito web o rivolgersi al proprio commerciante specializzato.

E Esta mesa está preparada para el reequipamiento con una estación de carga Qi para la carga inalámbrica de dispositivos electrónicos. Encontrará información detallada en nuestra página web u obténgala en su distribuidor especializado.

RUS Этот стол можно модернизировать зарядной станцией Qi для беспроводной зарядки электронный устройств. Подробную информацию можно найти на нашем сайте или получить у вашего дилера.

CHN 此书桌可升级选配无线充电装置，详情请参见官网或咨询经销商。

D

Reinigung und Pflege:

Wir empfehlen zur regelmäßigen Reinigung ein feuchtes Tuch und einen milden Haushaltsreiniger.

Bitte verwenden Sie keine Scheuermittel!

GB

Cleaning and care:

We recommend a damp cloth and a mild household cleaner for regular cleaning.

Please do not use abrasives!

F

Soin et entretien:

Pour un entretien régulier nous conseillons l'utilisation d'un chiffon légèrement humide et d'un produit d'entretien doux.

N'utilisez s.v.p aucun détergent ou produit abrasif !

I

Pulizia e manutenzione:

A tal fine raccomandiamo di utilizzare un panno umido e un detergente domestico delicato per la pulizia periodica.

Non utilizzare in nessun caso mezzi abrasivi!

E

Cuidados y limpieza:

Recomendamos para una limpieza regular emplear un trapo húmedo y un producto de limpieza doméstico suave.

Por favor, no emplee productos abrasivos.

RUS

Чистка и уход:

Мы рекомендуем регулярную очистку влажной тряпкой и мягким бытовым чистящим средством.

Не использовать абразивные средства!

CHN

清理和保养:

建议用湿布及家用柔和洗涤剂定期清洁。

不要使用强力去污剂!



Ersatzteilübersicht
List of spare parts
Vue d'ensemble des pièces de rechange
Elenco di ricambi

Champion Compact

05. 2020

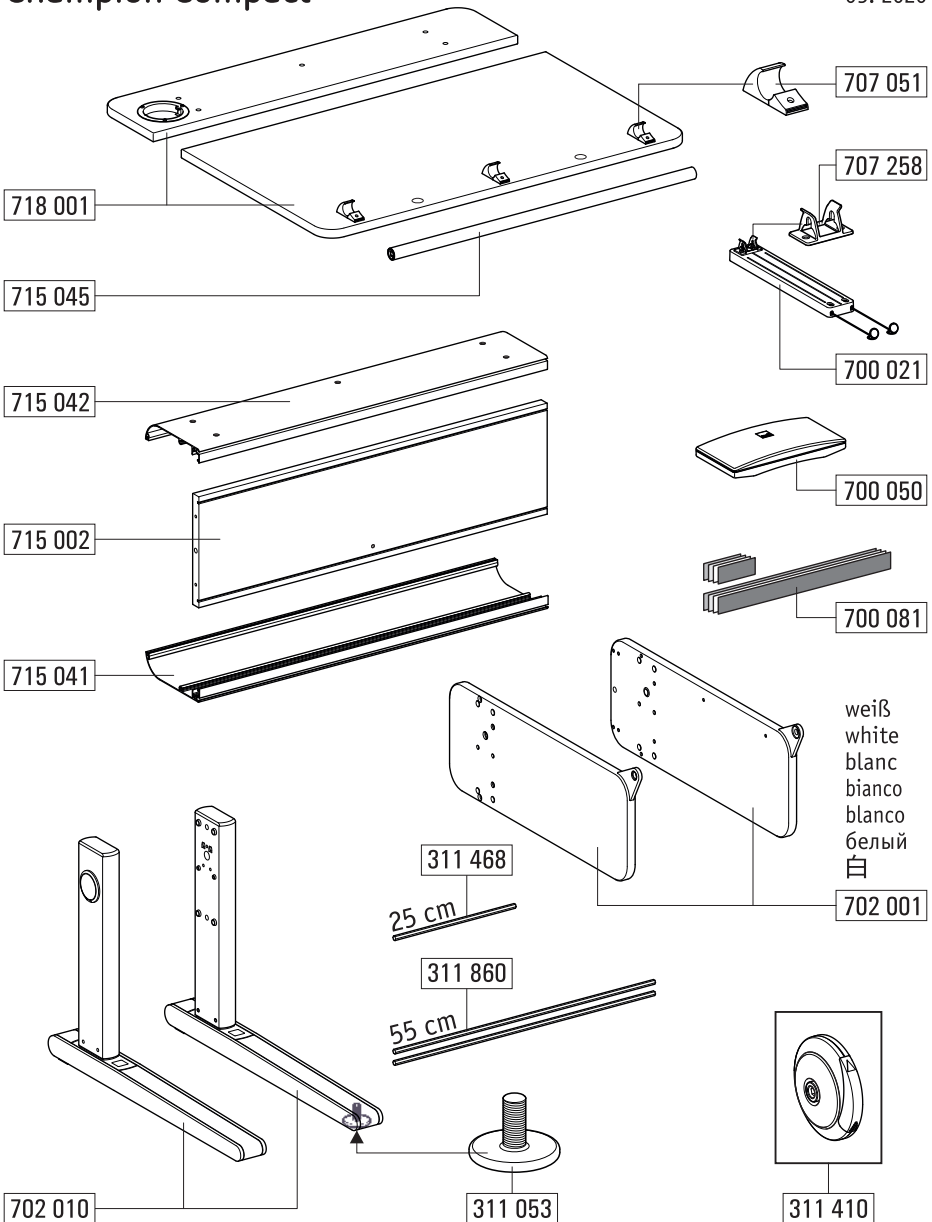

Lista de repuestos
 Обзор запасных частей
 备件清单

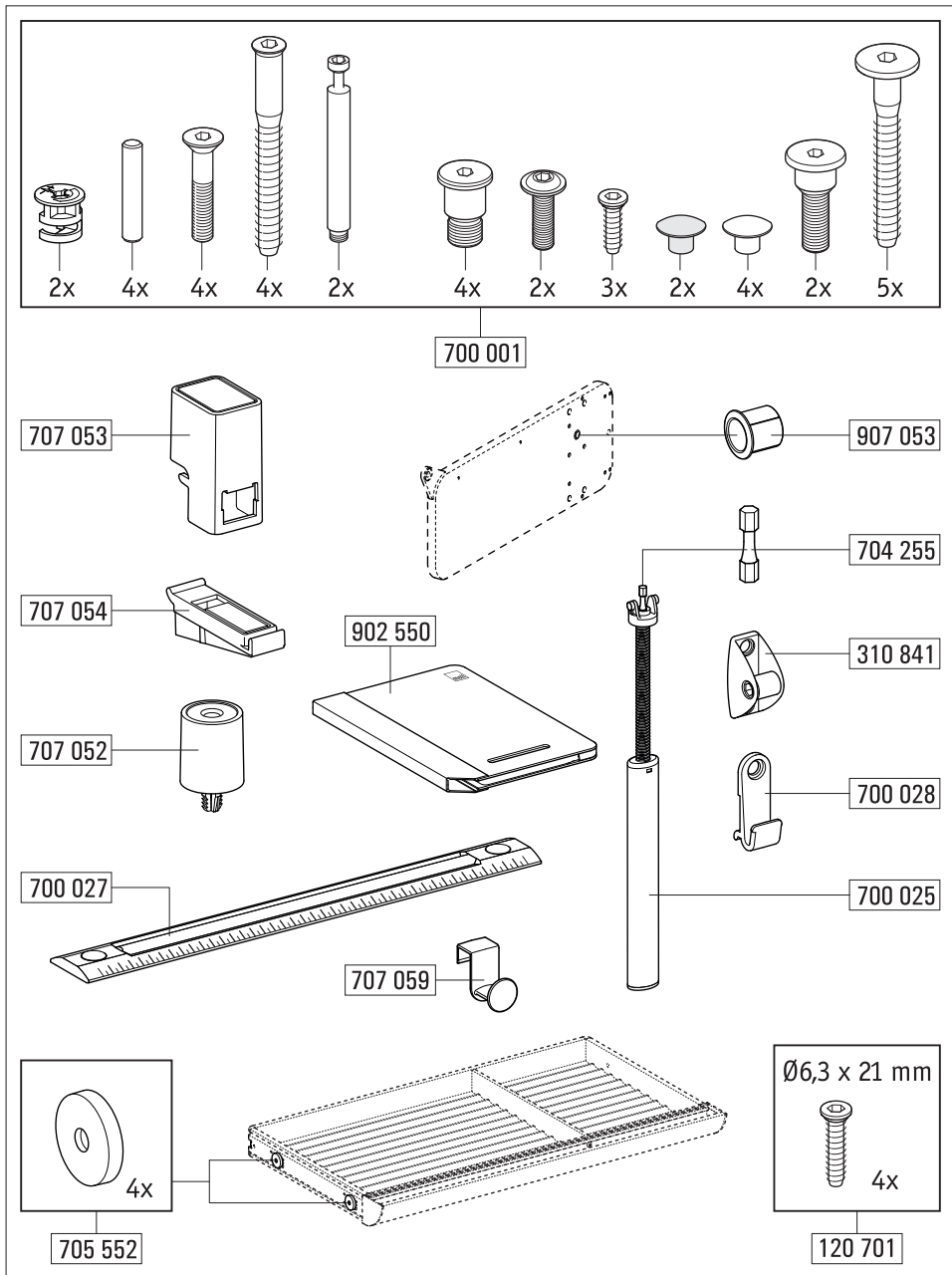

D Bitte bewahren Sie diese Montageanleitung auf!

GB Please carefully keep these assembly instructions

F Merci de conserver cette notice de montage!

I Si prega di conservare sempre le presenti istruzioni per il montaggio!

E Por favor, guarde estas instrucciones de montaje.

RUS Пожалуйста, храните данную инструкцию по монтажу

CHN 请妥善保存本组装说明!

服务地址 service@moll-funktion.de



moll Funktionsmöbel GmbH
Rechbergstraße 7
D 73344 Gruibingen

service@moll-funktion.de
www.moll-funktion.com

